



brilliant™

Be genuine collection

Quick Reference Guide

Model BL220B



FOR THE LOVE OF SEWING

To register your machine warranty and receive Baby Lock product updates and offers, go to babylock.com/login. If you have questions with registration, visit your Authorized Baby Lock Retailer.

Baby Lock Consumer Helpline: 800-313-4110

www.BabyLock.com

Before using your machine for the first time please read the “IMPORTANT SAFETY INSTRUCTIONS” in the Instruction and Reference Guide.

Refer to the instruction and reference guide for detailed instructions.

In this guide, English screens are used for basic explanations.

Antes de utilizar la máquina por primera vez, lea las “INSTRUCCIONES DE SEGURIDAD IMPORTANTES” en la Guía de referencia y de instrucciones.

Consulte las instrucciones detalladas en la guía de referencia y de instrucciones.

En esta guía, para las explicaciones básicas se utilizan pantallas en inglés.

Avant d'utiliser votre machine pour la première fois, veuillez lire les « INSTRUCTIONS DE SÉCURITÉ IMPORTANTES » indiquées dans le guide d'instructions et de référence.

Reportez-vous au guide d'instructions et de référence pour des informations détaillées.

Les écrans de ce guide sont en anglais pour les explications de base.

Contents

Accessories	2
◆ Included Accessories	2
◆ Optional Accessories	2
Bobbin Winding and Setting	6
Upper Threading	8
Name of Machine Parts	10
◆ Operation buttons	10
◆ Operation panel	11
◆ Settings screen	12
Selecting and Sewing Patterns	13
◆ Preset Utility Stitches	13
◆ Utility Stitches	14
◆ Decorative Stitches	15
◆ Character stitches	15
Summary of Stitch Patterns	16
◆ Preset Utility Stitches	16
◆ Utility Stitches	16
◆ Decorative Stitches	16
◆ Character Stitches	17

Contenido

Accesorios	2
◆ Accesorios incluidos	2
◆ Accesorios opcionales	2
Bobinado y ajuste	6
Hilo superior	8
Nombres de las piezas de la máquina	10
◆ Botones de operación	10
◆ Panel de operaciones	11
◆ Pantalla de ajustes	12
Seleccionar y coser patrones	13
◆ Puntadas de utilidad predefinidas	13
◆ Puntadas de utilidad	14
◆ Puntadas decorativas	15
◆ Puntadas de carácter	15
Resumen de tipos de puntada	16
◆ Puntadas de utilidad predefinidas	16
◆ Puntadas de utilidad	16
◆ Puntadas decorativas	16
◆ Puntadas de carácter	17

Table des matières



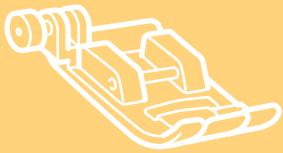







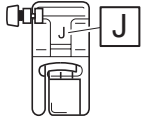
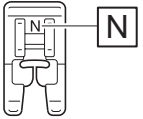
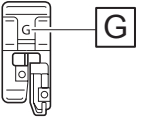
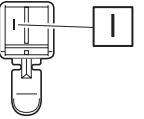
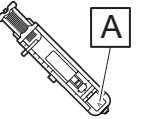
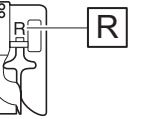
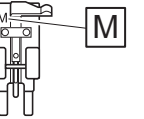
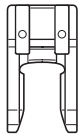

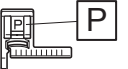
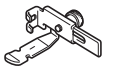
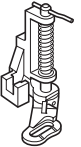
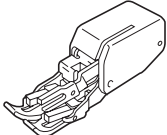
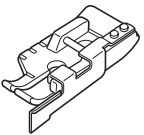



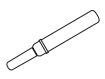

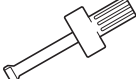
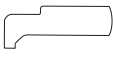





Accessoires	4
◆ Accessoires inclus	4
◆ Accessoires en option	4
Bobinage et réglage de la canette	6
Enfilage supérieur	8
Nom des pièces de la machine	10
◆ Touches de commande	10
◆ Panneau de commande	11
◆ Écran de réglages	12
Sélection et couture de motifs	13
◆ Préréglage des points de couture courants	13
◆ Points de couture courants	14
◆ Points décoratifs	15
◆ Points de caractères	15
Sommaire des motifs de point	16
◆ Préréglage des points de couture courants	16
◆ Points de couture courants	16
◆ Points décoratifs	16
◆ Points de caractères	17



Accessories

Accesorios

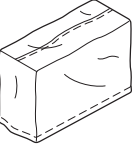

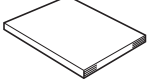
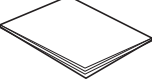



◆ Included Accessories ◆ Accesorios incluidos

1. 	2. 	3. 	4. 	5. 	6. 	7. 	
8. 	9. 	10. 	11. 	12. 	13. 	14. 	
15.*1 	16.*2 	17. 	18. 	19. 	20. 	21. 	
22. 	23. 	24. 	25. 	26. 	27. 	28. 	
29. 	30. 	31. 	32. 	33. 	34. 	35. 	
36. 	37. 	38. 	39. 				

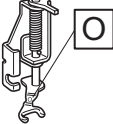
*1 75/11 2 needles, 90/14 2 needles, 90/14 2 needles: Ball point needle (gold colored)
 *2 2.0/11 needle

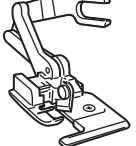
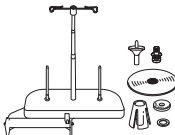
*1 2 agujas 75/11, 2 agujas 90/14, 2 agujas 90/14: aguja de punta redonda (color dorado)
 *2 Aguja 2,0/11

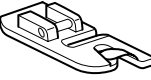
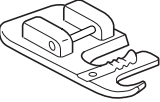
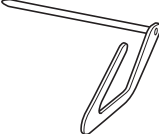
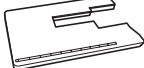
◆ Optional Accessories ◆ Accesorios opcionales

1. 	2. 	3. 	4. 	5. 	6. 	7. 
8. 	9. 	10. 				

◆ Included Accessories

No.	Part Name	Part Code
1	Zigzag foot "J" (on machine)	XF9671-001
2	Monogramming foot "N"	XD0810-031
3	Overcasting foot "G"	XC3098-031
4	Zipper foot "I"	X59370-021
5	Buttonhole foot "A"	XC2691-023
6	Blind stitch foot "R"	XE2650-001
7	Button fitting foot "M"	XE2643-001
8	Open toe foot	FA7
9	Non stick foot	FA8
10	Stitch guide foot "P"	FA6
11	Adjustable zipper/piping foot	FA9
12	Quilting foot	FA2
13	Walking foot	BLG-WF
14	1/4" quilting foot with guide	ESG-QGF
15	Needle set	X58358-021
16	Twin needle	X59296-121
17	Bobbin (4) (One is on machine)	X52800-120
18	Seam ripper	XF4967-001
19	Cleaning brush	X59476-051
20	Eyelet punch	XZ5051-001
21	Screwdriver (large)	XC4237-021
22	L-shaped screwdriver	XG0918-001
23	Disc-shaped screwdriver	XC1074-051
24	Horizontal spool pin	XC4654-151
25	Spool cap (large)	130012-024
26	Spool cap (medium) (2) (One is on machine)	XE1372-001
27	Spool cap (small)	130013-124
28	Thread spool insert (mini king thread spool)	XA5752-121
29	Spool net	XA5523-020
30	Knee lifter	XA6941-052
31	Bobbin case (on machine)	XG2058-001
32	Foot controller	XZ5100-001
33	Accessory bag	XC4487-021
34	Bobbin cover (with mark) (on machine)	XF0750-101
35	Bobbin cover	XE8992-101
36	Dust cover	XF9110-001
37	Power cord	XC6052-021
38	Instruction and Reference Guide	XG3158-001
39	Quick reference guide	XG3159-001



Note

- The presser foot holder screw is available through your authorized Babylock retailer. (Part code: XG1343-001)
- The presser foot accessory tray is available, through your authorized retailer. (Part code: XF8650-001)

◆ Optional Accessories

The following are available as optional accessories to be purchased separately from your authorized Baby Lock retailer.

No.	Part Name	Part Code
1	Free motion open toe quilting foot "O"	BLSR-FMO
2	1/4" quilting foot	FA1
3	Side cutter "S"	BLG-SCF
4	Spool stand	BLMAC-ST5
5	Straight stitch foot and needle plate set	BLMAC-SS
6	Narrow hemmer foot	ESG-HF
7	Cording foot (3 cord guide)	BLG-CF3
8	Quilting guide	BLG-QG
9	Extension table	BLMAC-ET
10	Edge joining foot	ESG-EJF



Memo

- To obtain optional accessories or parts, contact your authorized Babylock retailer.
- All specifications are correct at the time of printing. Please be aware that some specifications may change without notice.
- Visit your nearest authorized Babylock retailer for a complete listing of optional accessories available for your machine.
- Always use accessories recommended for this machine.

◆ Accesorios incluidos

Nº	Nombre de la pieza	Código de la pieza
1	Pie para zig-zag "J" (en la máquina)	XF9671-001
2	Pie para monogramas "N"	XD0810-031
3	Pie para sobrehilado "G"	XC3098-031
4	Pie para cremalleras "I"	X59370-021
5	Pie para ojales "A"	XC2691-023
6	Pie para puntada invisible "R"	XE2650-001
7	Pie especial para botones "M"	XE2643-001
8	Pie de punta abierta	FA7
9	Pie antiadherente	FA8
10	Pie para guía de puntadas "P"	FA6
11	Pie ajustable para cremalleras/ribetes	FA9
12	Pie para acolchados	FA2
13	Pie móvil	BLG-WF
14	Pie para acolchado de 1/4" con guía	ESG-QGF
15	Juego de agujas	X58358-021
16	Aguja gemela	X59296-121
17	Bobina (4) (Una está colocada en la máquina)	X52800-120
18	Abreojales	XF4967-001
19	Cepillo de limpieza	X59476-051
20	Lápiz calador	XZ5051-001
21	Destornillador (grande)	XC4237-021
22	Destornillador en forma de L	XG0918-001
23	Destornillador de disco	XC1074-051
24	Portacarrete horizontal	XC4654-151
25	Tapa del carrete (grande)	130012-024
26	Tapa del carrete (mediana) (2) (Una está colocada en la máquina)	XE1372-001
27	Tapa de carrete (pequeña)	130013-124
28	Inserción del carrete de hilo (carrete de hilo "mini king")	XA5752-121
29	Red para carrete	XA5523-020
30	Elevador de rodilla	XA6941-052
31	Caja de la bobina (en la máquina)	XG2058-001
32	Pedal	XZ5100-001
33	Bolsa de accesorios	XC4487-021
34	Tapa de la bobina (con marca) (en la máquina)	XF0750-101
35	Tapa de bobina	XE8992-101
36	Funda	XF9110-001
37	Cable de alimentación	XC6052-021
38	Guía de referencia y de instrucciones	Contacto con su distribuidor Baby Lock.
39	Guía de referencia rápida	XG3159-001



Nota

- Puede adquirir el tornillo del soporte del pie prensatela en su distribuidor Babylock autorizado. (Referencia: XG1343-001)
- Puede adquirir la bandeja de accesorios del pie prensatela en su distribuidor autorizado. (Referencia: XF8650-001)

◆ Accesorios opcionales

En la tabla siguiente se presentan los accesorios opcionales disponibles que pueden adquirirse por separado en su distribuidor Baby Lock autorizado.

Nº	Nombre de la pieza	Código de la pieza
1	Pie para acolchado libre de punta abierta "O"	BLSR-FMO
2	Pie para acolchado de 1/4"	FA1
3	Cuchilla lateral "S"	BLG-SCF
4	Pora hilos grande	BLMAC-ST5
5	Pie de costura recta y juego de placas de la aguja	BLMAC-SS
6	Pie para dobladillos estrechos	ESG-HF
7	Pie para cordones (guía de 3 cordones)	BLG-CF3
8	Quilting guide	BLG-QG
9	Tablero de extensión	BLMAC-ET
10	Pie para unir bordes	ESG-EJF







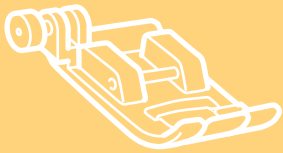





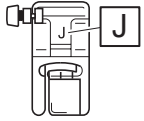
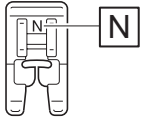
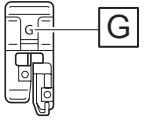
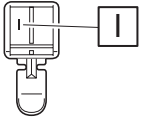
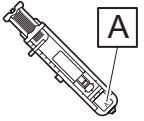
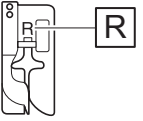
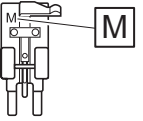
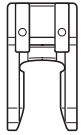

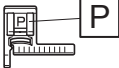
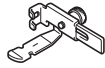
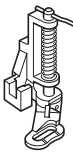
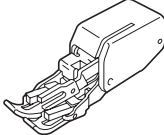
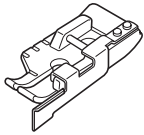



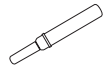

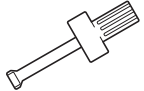
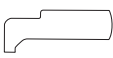









Recuerde

- Si desea obtener accesorios o piezas opcionales, póngase en contacto con su distribuidor Babylock autorizado.
- Todas las especificaciones son correctas en el momento de la publicación. Tenga en cuenta que algunas especificaciones pueden sufrir cambios sin previo aviso.
- Póngase en contacto con su distribuidor Babylock autorizado más cercano para obtener una lista completa de los accesorios opcionales disponibles para su máquina.
- Utilice siempre los accesorios recomendados para esta máquina.

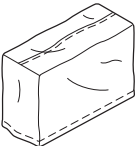







Accessoires

◆ Accessoires inclus

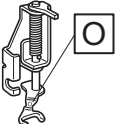
1.  J	2.  N	3.  G	4.  I	5.  A	6.  R	7.  M
8. 	9. 	10.  P	11. 	12. 	13. 	14. 
15.*1 	16.*2 	17. 	18. 	19. 	20. 	21. 
22. 	23. 	24. 	25. 	26. 	27. 	28. 
29. 	30. 	31. 	32. 	33. 	34. 	35. 
36. 	37. 	38. 	39. 	40. 	41. 	42. 

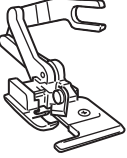
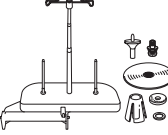
*1 2 aiguilles 75/11, 2 aiguilles 90/14, 2 aiguilles 90/14 : aiguille à pointe boule (dorée)
*2 aiguille 2,0/11

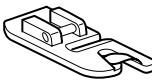
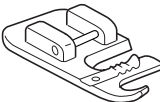
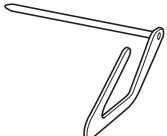
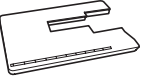
◆ Accessoires en option

1.  O	2. 	3. 	4. 	5. 	6. 	7. 
8. 	9. 	10. 				

◆ Accessoires inclus

N°	Nom de la pièce	Code de la pièce
1	Pied zigzag « J » (sur la machine)	XF9671-001
2	Pied pour monogrammes « N »	XD0810-031
3	Pied pour faufilage « G »	XC3098-031
4	Pied pour fermetures à glissière « I »	X59370-021
5	Pied pour boutons « A »	XC2691-023
6	Pied pour point invisible « R »	XE2650-001
7	Pied pour boutons « M »	XE2643-001
8	Pied ouvert	FA7
9	Pied-de-biche non adhérent	FA8
10	Pied-de-biche de guidage de points « P »	FA6
11	Pied réglable pour fermetures à glissière/ passepoils	FA9
12	Pied pour quilting (courtepointe)	FA2
13	Pied à double entraînement	BLG-WF
14	Guide et pied pour quilting (courtepointe) 1/4" / pouce	ESG-QGF
15	Jeu d'aiguilles	X58358-021
16	Aiguille jumelée	X59296-121
17	Canette x 4 (l'une se trouve sur la machine)	X52800-120
18	Découpeur	XF4967-001
19	Brosse de nettoyage	X59476-051
20	Perce-œillet	XZ5051-001
21	Tournevis (grand)	XC4237-021
22	Tournevis en forme de L	XG0918-001
23	Tournevis en forme de disque	XC1074-051
24	Porte-bobine horizontal	XC4654-151
25	Couvercle de bobine (grand)	130012-024
26	Couvercle de bobine (moyen) x 2 (l'un se trouve sur la machine)	XE1372-001
27	Couvercle de bobine (petit)	130013-124
28	Centre amovible pour bobine de fil (bobine de fil mini/très grand)	XA5752-121
29	Filet de la bobine	XA5523-020
30	Genouillère	XA6941-052
31	Boîtier de la canette (sur la machine)	XG2058-001
32	Pédale	XZ5100-001
33	Sac d'accessoires	XC4487-021
34	Capot du compartiment à canette (avec un repère) (sur la machine)	XF0750-101
35	Capot du compartiment à canette	XE8992-101
36	Housse	XF9110-001
37	Cordon d'alimentation	XC6052-021
38	Guide d'instructions et de référence	Contactez votre revendeur Baby Lock.
39	Guide de référence rapide	XG3159-001



Remarque

- La vis du support du pied-de-biche est disponible auprès de votre revendeur Babylock agréé. (code de référence : XG1343-001)
- Le tiroir d'accessoires pour pied-de-biche est disponible auprès de votre revendeur agréé. (code de référence : XF8650-001)

◆ Accessoires en option

Les éléments suivants sont des accessoires en option vendus séparément par votre revendeur Baby Lock agréé.

N°	Nom de la pièce	Code de la pièce
1	Pied pour quilting (courtepointe) ouvert en mouvement libre « O »	BLSR-FMO
2	Pied pour quilting (courtepointe) 1/4" / pouce	FA1
3	Couteau raseur « S »	BLG-SCF
4	Porte multi-bobines	BLMAC-STS
5	Ensemble pied pour point droit et plaque à aiguille	BLMAC-SS
6	Pied ourleur étroit	ESG-HF
7	Pied pour cordonnet (guide 3 cordonnets)	BLG-CF3
8	Guide pour quilting (courtepointe)	BLG-QG
9	Table d'extension	BLMAC-ET
10	Pied pour l'assemblage des bords	ESG-EJF



Mémo

- Pour obtenir les pièces ou les accessoires en option, contactez votre revendeur Babylock agréé.
- Toutes les spécifications sont correctes à la date d'impression de ce document. Certaines spécifications peuvent être modifiées sans avis préalable.
- Consultez votre revendeur Babylock agréé le plus proche pour obtenir la liste complète des accessoires en option pour votre machine.
- Utilisez toujours des accessoires recommandés pour cette machine.



Bobbin Winding and Setting

Bobinado y ajuste

Bobinage et réglage de la canette

Follow the steps below, in numerical order. Refer to the instruction and reference guide for detailed instructions.
 Siga los pasos descritos a continuación, en orden numérico. Consulte las instrucciones detalladas en la guía de referencia y de instrucciones.
 Respectez les étapes ci-dessous, dans l'ordre numérique. Reportez-vous au guide d'instructions et de référence pour des informations détaillées.

Use only the included bobbin or bobbins of the same type.
 Utilice solo la bobina incluida, o bobinas del mismo tipo.
 N'utilisez que la canette fournie ou des canettes du même type.

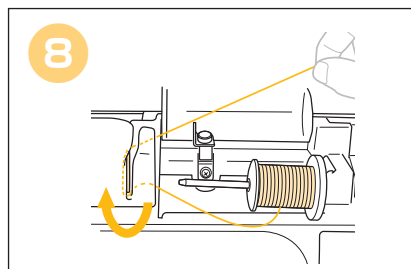
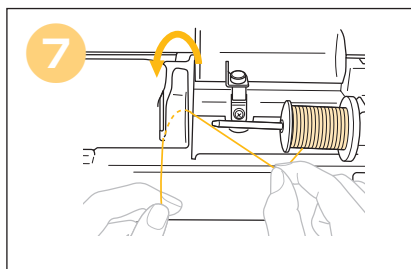
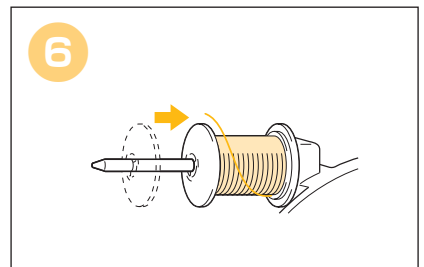
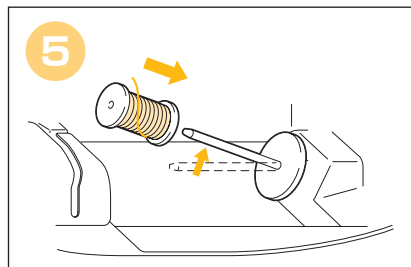
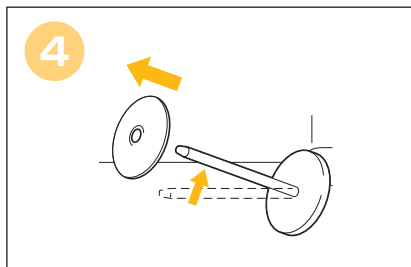
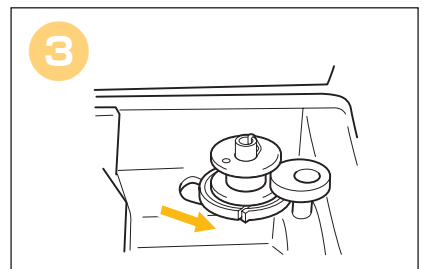
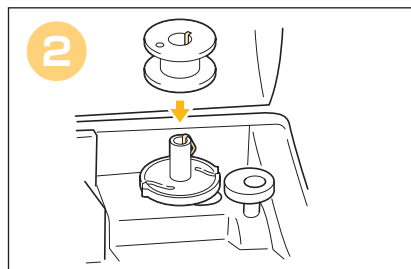
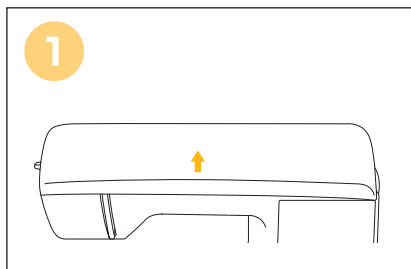
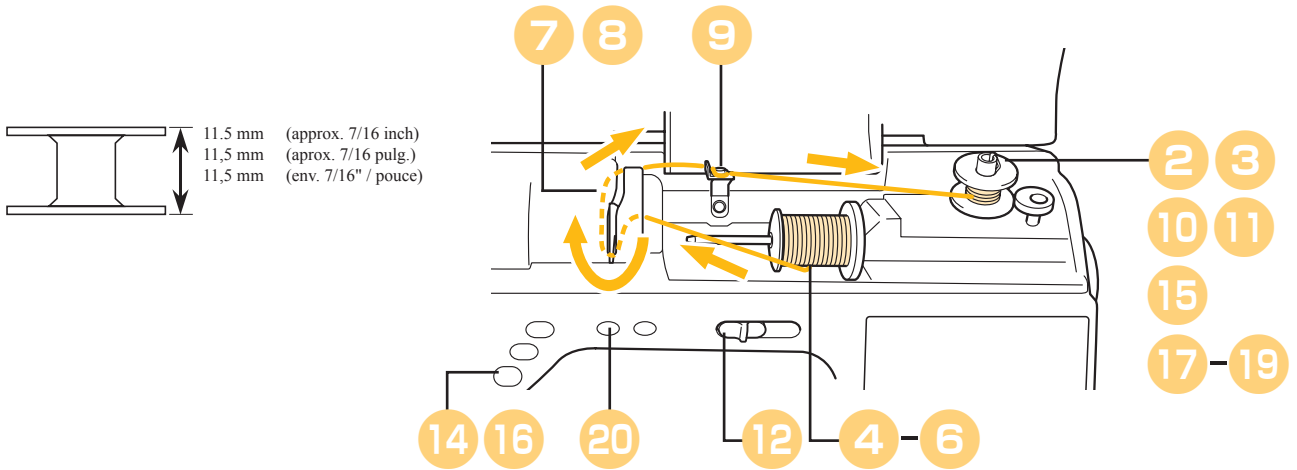

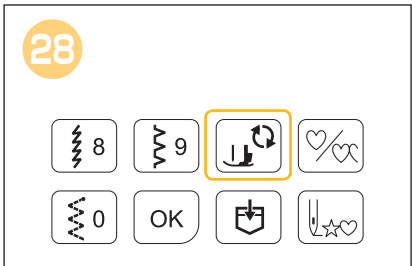
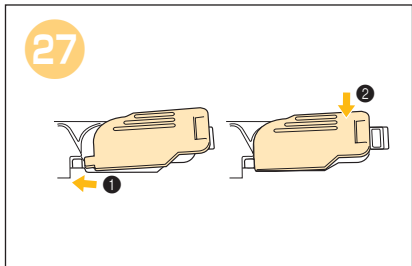
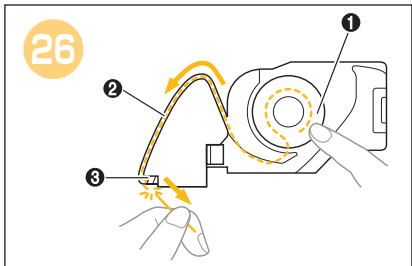
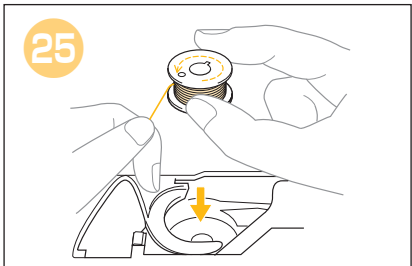
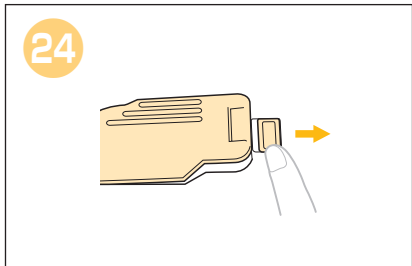
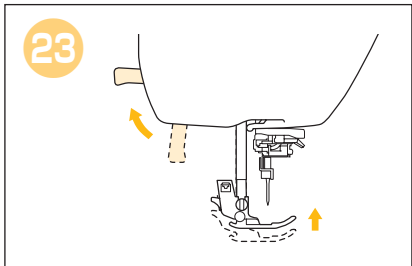
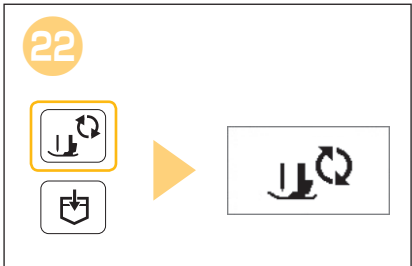
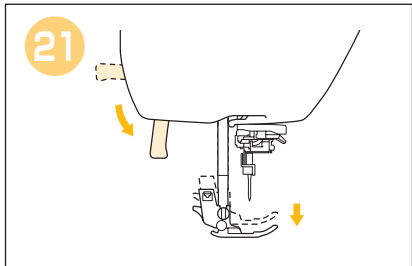
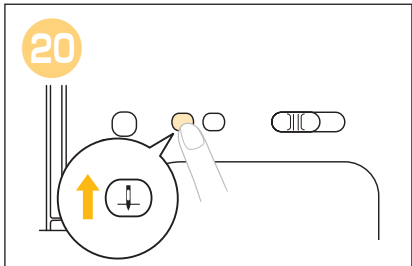
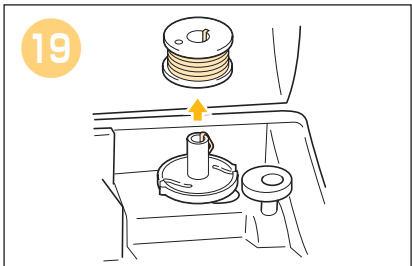
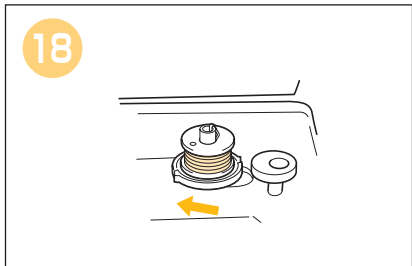
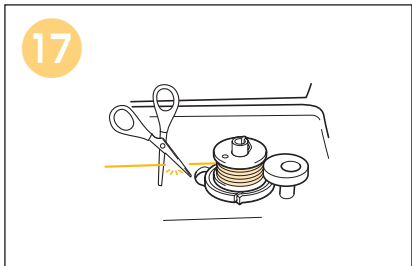
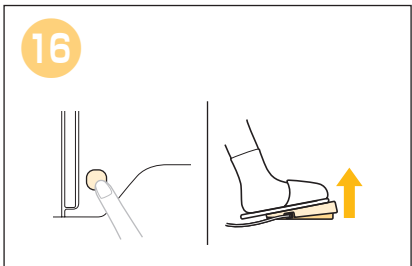
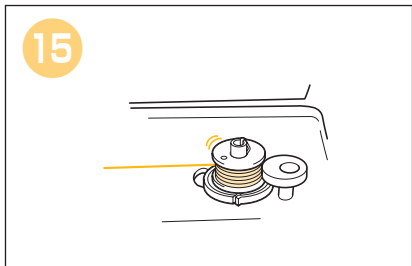
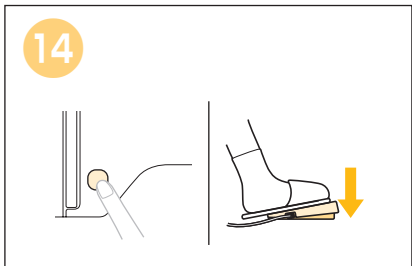
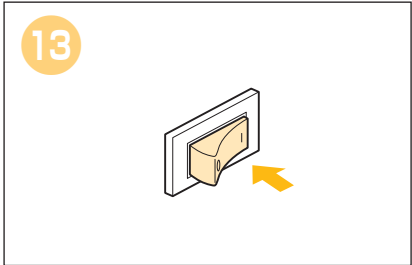
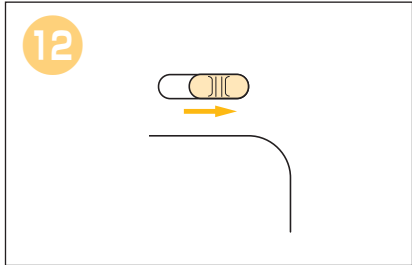
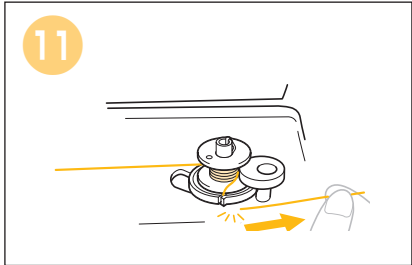
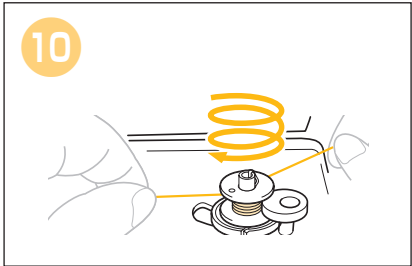
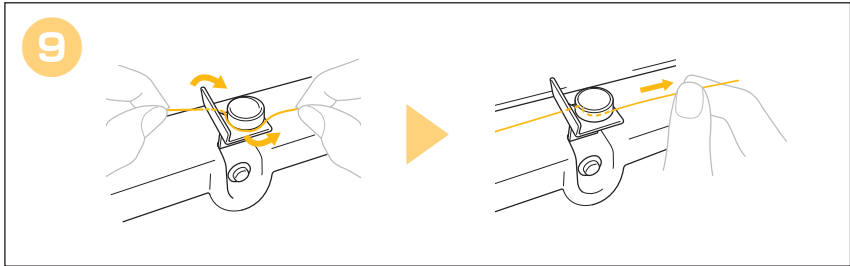



Upper Threading Hilo superior Enfilage supérieur

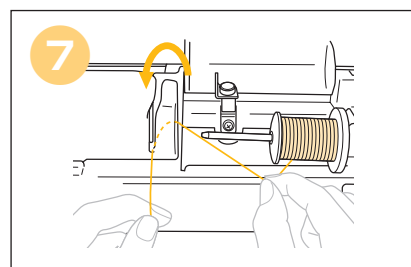
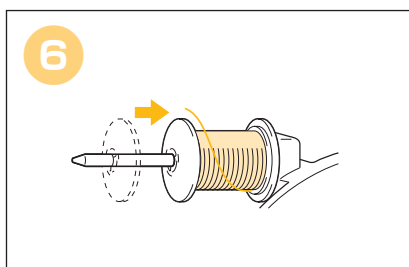
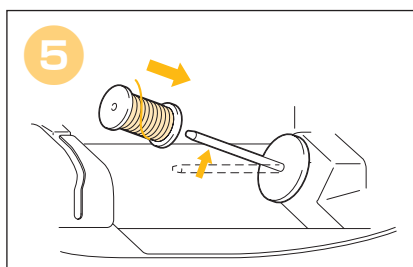
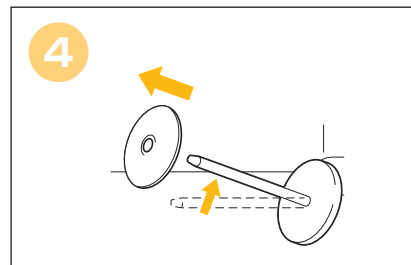
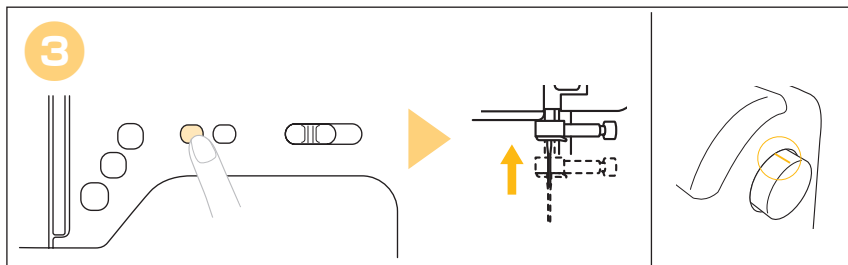
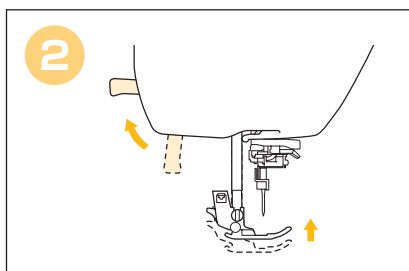
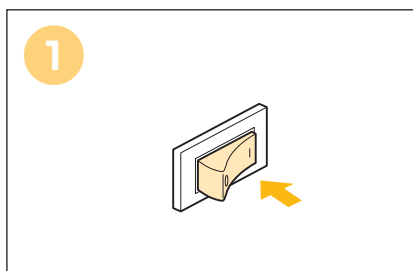
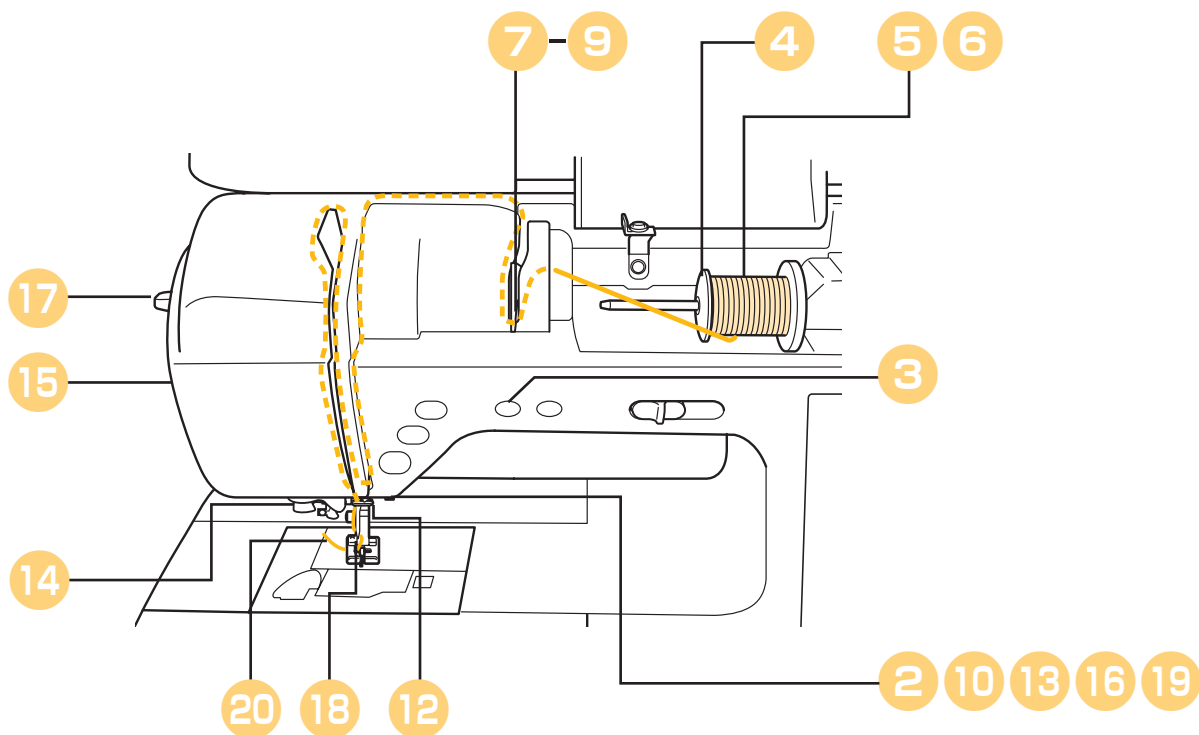

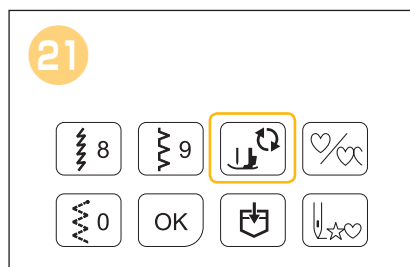
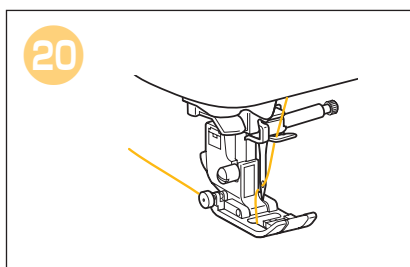
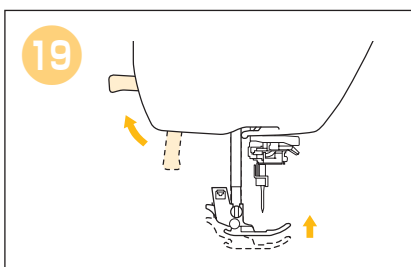
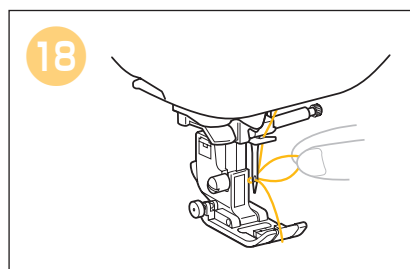
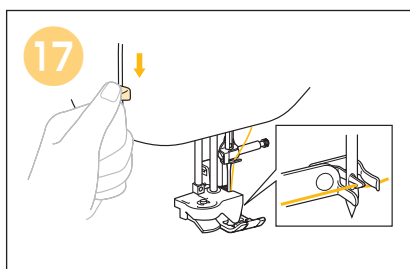
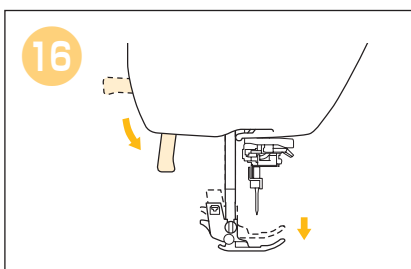
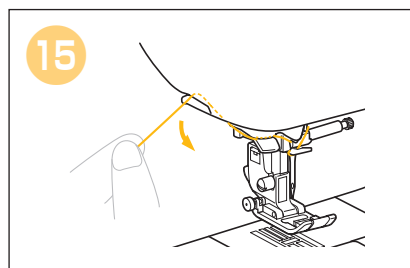
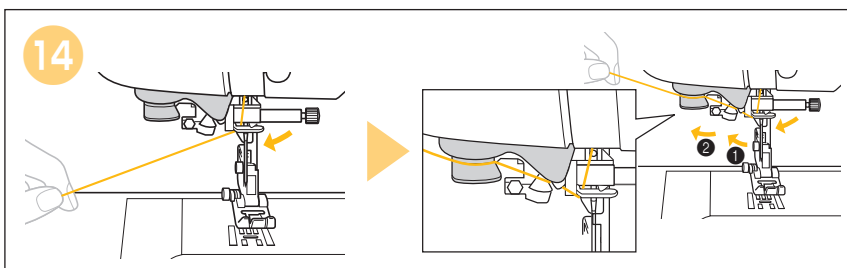
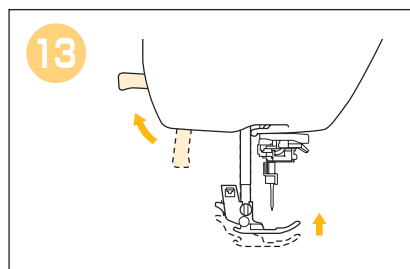
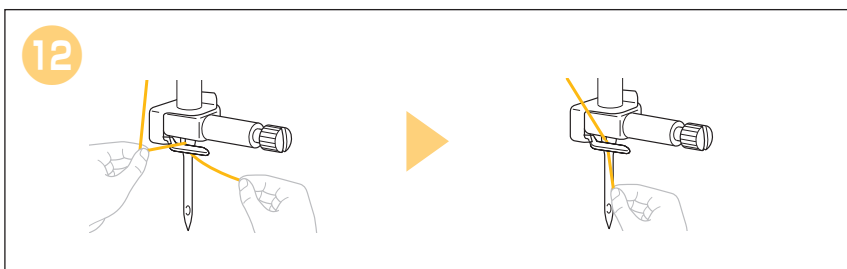
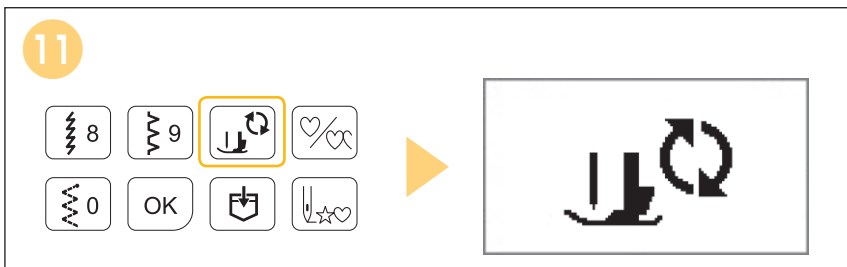
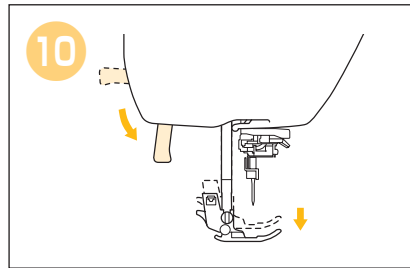
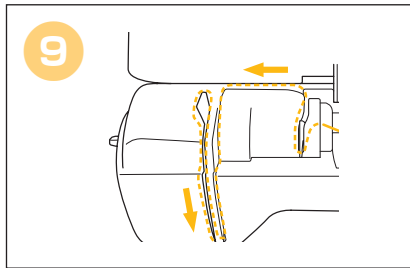
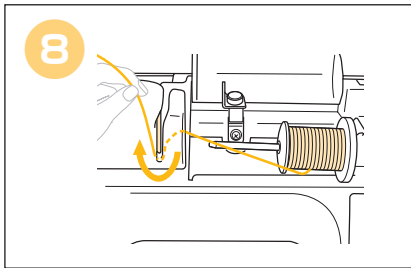



Name of Machine Parts Nombres de las piezas de la máquina Nom des pièces de la machine

◆ Operation buttons ◆ Botones de operación ◆ Touches de commande

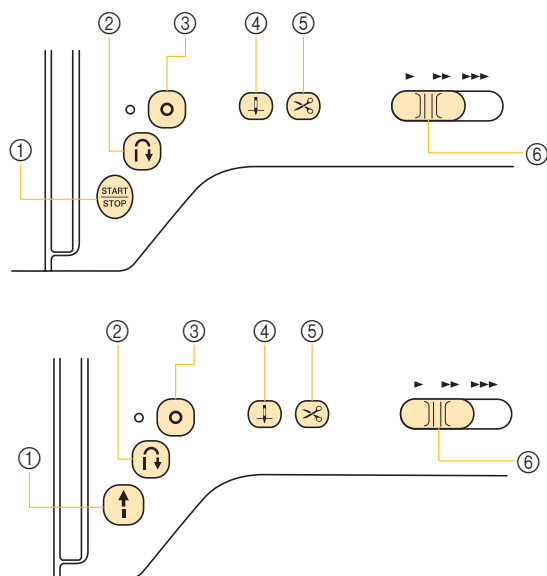

- ① "Start/Stop" button
- ② Reverse stitch button
- ③ Reinforcement stitch button
- ④ Needle position button
- ⑤ Thread cutter button
- ⑥ Sewing speed controller/Width control

- ① Botón de "inicio/parar"
- ② Botón de puntada en reversa
- ③ Botón de puntada de remate
- ④ Botón de posición de aguja
- ⑤ Botón de corte de hilo
- ⑥ Control de velocidad manual/Control de anchura

- ① Touche « Marche/arrêt »
- ② Touche Point inverse
- ③ Touche Point de renfort
- ④ Touche Positionnement aiguille
- ⑤ Touche Coupe-fil
- ⑥ Commande de vitesse de couture/Contrôle de la largeur

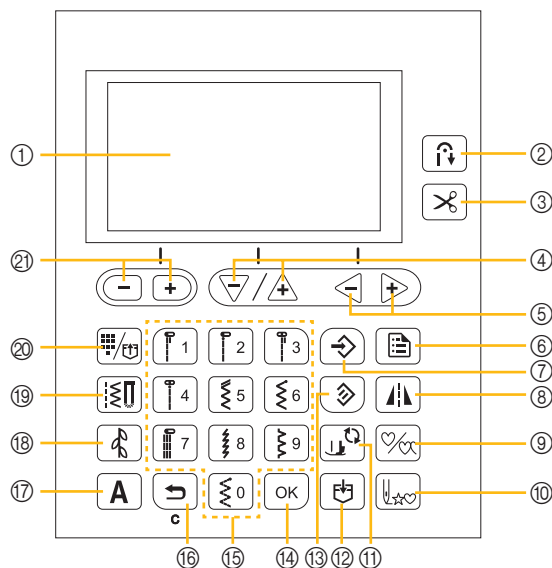

- ① LCD (liquid crystal display)
- ② Automatic reverse/reinforcement key
- ③ Automatic thread cutting key
- ④ Stitch length keys/Item selection keys
- ⑤ Value selection keys
- ⑥ Settings key
- ⑦ Manual memory key
- ⑧ Mirror image key
- ⑨ Single/repeat sewing key
- ⑩ Back to beginning key
- ⑪ Presser foot/Needle exchange key
- ⑫ Memory key
- ⑬ Reset key
- ⑭ OK key
- ⑮ Numeric keys
- ⑯ Back key
- ⑰ Character stitch key
- ⑱ Decorative stitch key
- ⑲ Utility stitch key
- ⑳ Preset utility stitch/saved pattern key
- ㉑ Stitch width keys/Settings screen page selection keys

- ① Pantalla LCD (pantalla de cristal líquido)
- ② Tecla de puntada en reversa/remate automática
- ③ Tecla de corte automático de hilo
- ④ Teclas de longitud de la puntada/Teclas de selección de elemento
- ⑤ Teclas de selección de valor
- ⑥ Tecla de ajustes
- ⑦ Tecla de memoria manual
- ⑧ Tecla de efecto espejo
- ⑨ Tecla de costura sencilla/doble
- ⑩ Tecla para volver al principio
- ⑪ Tecla de cambio del pie prensatela/aguja
- ⑫ Tecla de memoria
- ⑬ Tecla de borrado
- ⑭ Tecla Aceptar
- ⑮ Teclas numéricas
- ⑯ Tecla de retroceso
- ⑰ Tecla de puntada de carácter
- ⑱ Tecla de puntada decorativa
- ⑲ Tecla de puntada de utilidad
- ⑳ Tecla de puntada de utilidad predefinida/patrón guardado
- ㉑ Teclas de anchura de la puntada/Teclas de selección de página de la pantalla de ajustes

- ① Écran à cristaux liquides
- ② Touche de point inverse/de renfort automatique
- ③ Touche de coupure de fil automatique
- ④ Touches de longueur de point/Touches de sélection d'élément
- ⑤ Touches de sélection de valeur
- ⑥ Touche de réglages
- ⑦ Touche de mémoire manuelle
- ⑧ Touche d'image en miroir
- ⑨ Touche de couture en points uniques/en continu
- ⑩ Retour à la touche de début
- ⑪ Touche de remplacement du pied-de-biche/de l'aiguille
- ⑫ Touche de mise en mémoire
- ⑬ Touche de réinitialisation
- ⑭ Touche OK
- ⑮ Touches numériques
- ⑯ Touche arrière
- ⑰ Touche de points de caractères
- ⑱ Touche de points décoratifs
- ⑲ Touche de points de couture courants
- ⑳ Touche de préréglage de point de couture courant/motif enregistré
- ㉑ Touches de largeur de point/Touches de sélection des pages de l'écran de réglages

◆ Settings screen ◆ Pantalla de ajustes ◆ Écran de réglages

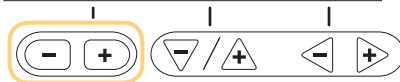
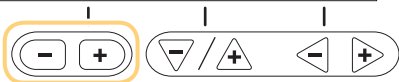
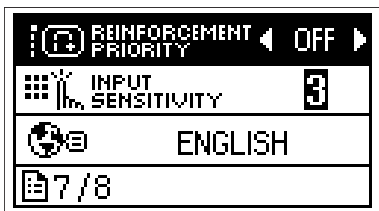
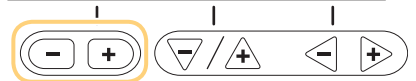
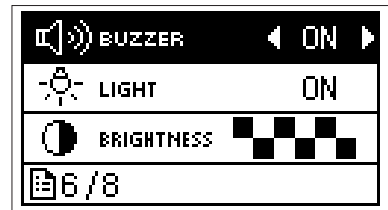
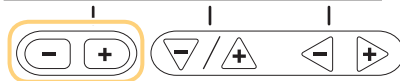
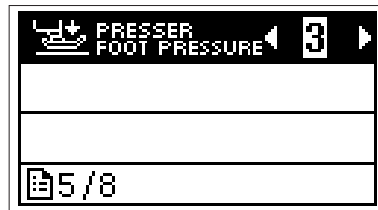
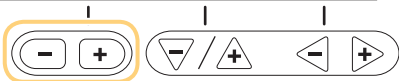
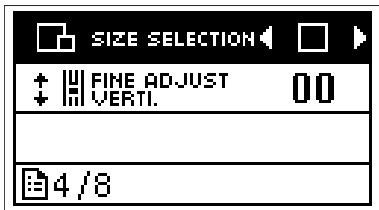
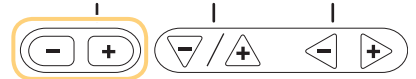
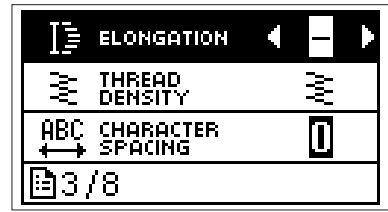
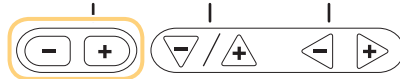
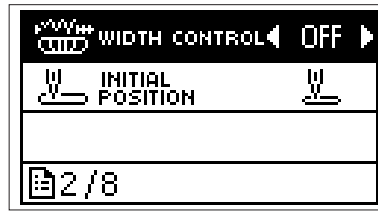
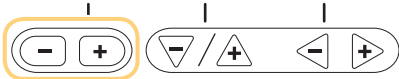
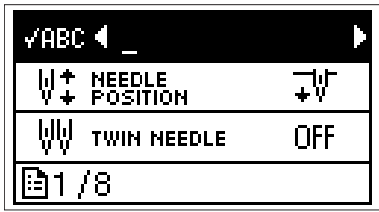
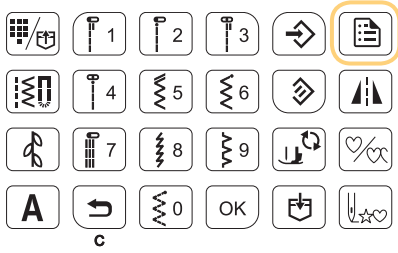

Selecting and Sewing Patterns

Seleccionar y coser patrones

Sélection et couture de motifs

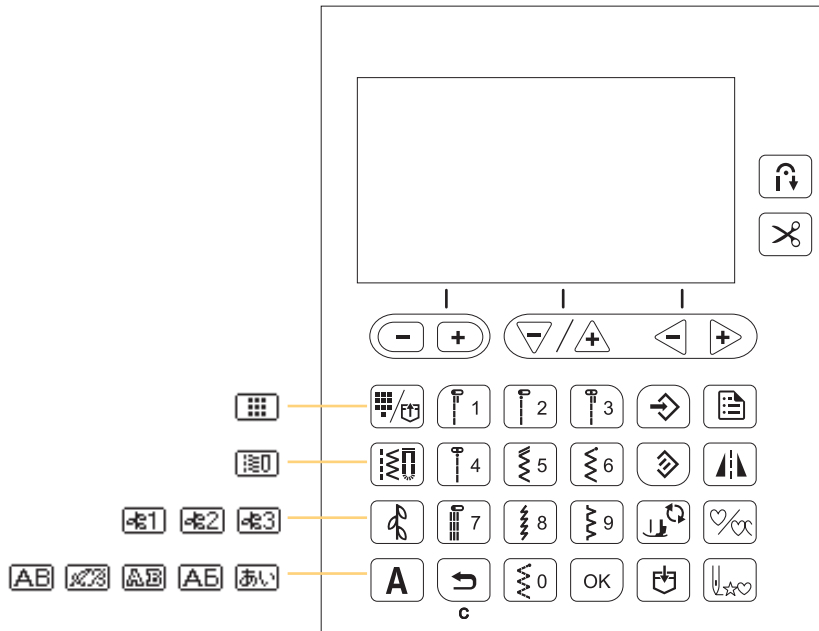

◆ Preset Utility Stitches ◆ Puntadas de utilidad predefinidas ◆ Préréglage des points de couture courants

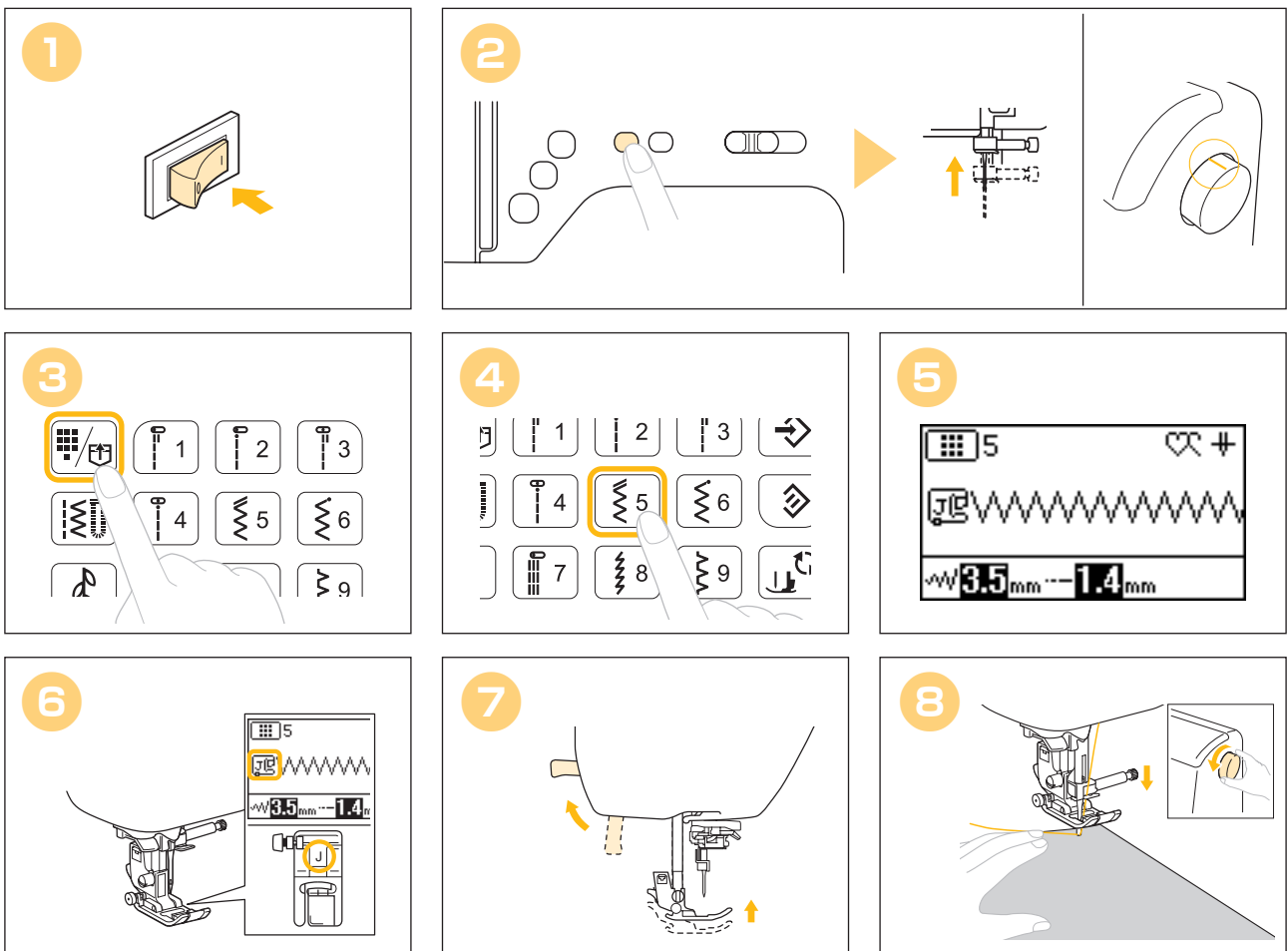

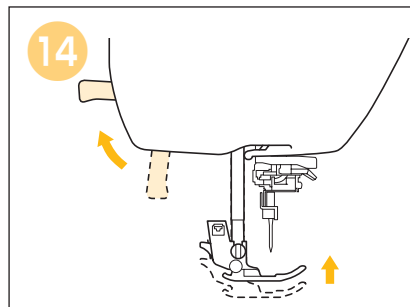
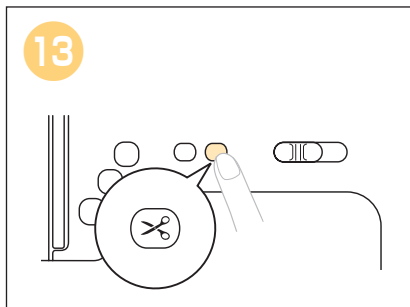
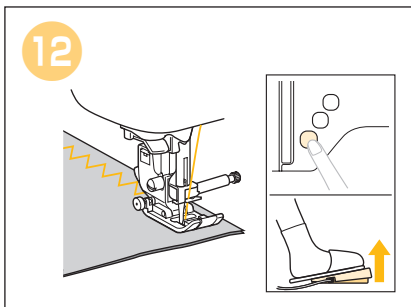
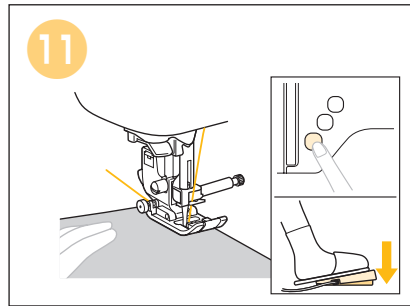
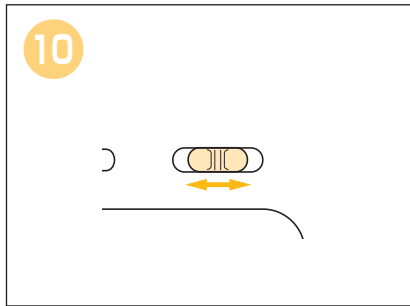
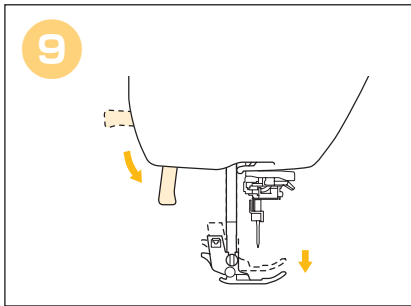

◆ Utility Stitches

◆ Puntadas de utilidad

◆ Points de couture courants

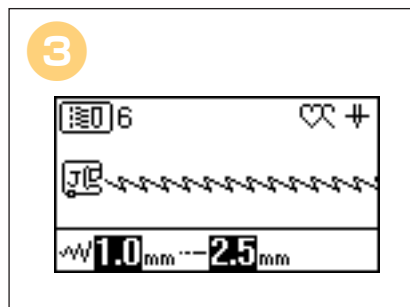
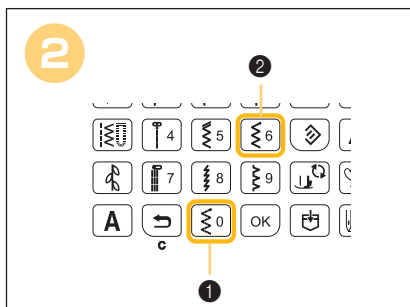
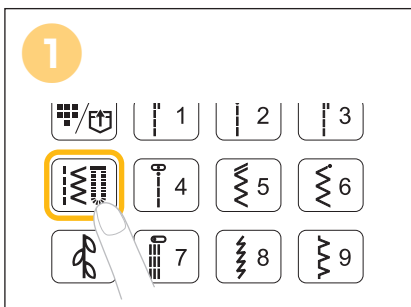

◆ Decorative Stitches ◆ Puntadas decorativas ◆ Points décoratifs

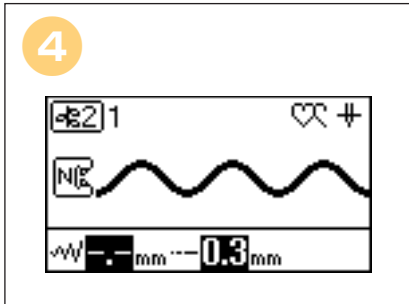
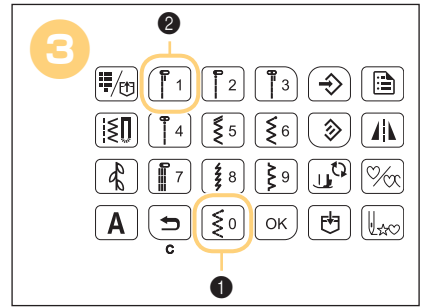
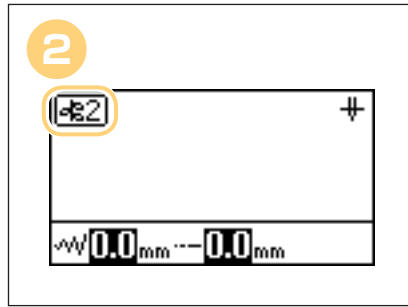
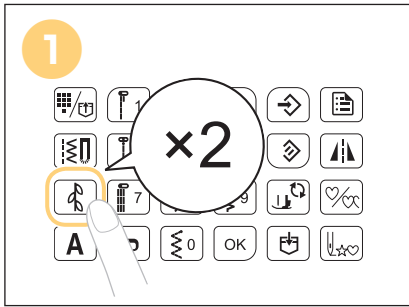

◆ Character stitches ◆ Puntadas de carácter ◆ Points de caractères

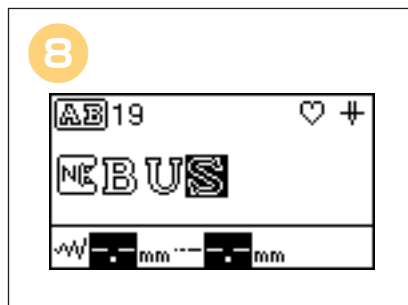
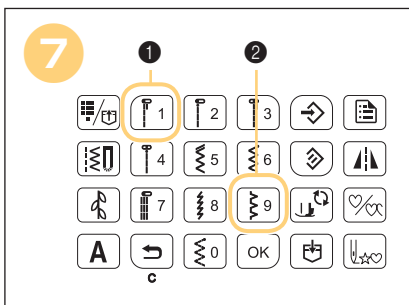
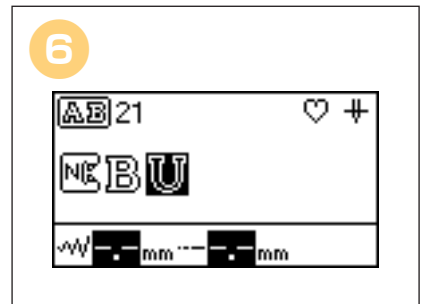
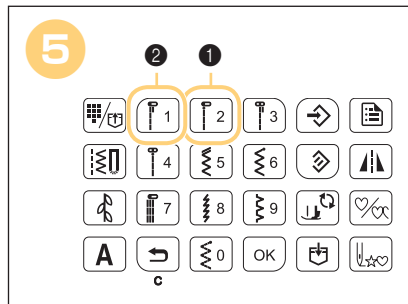
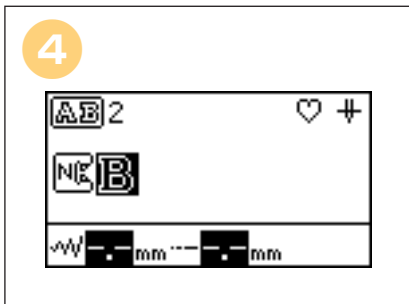
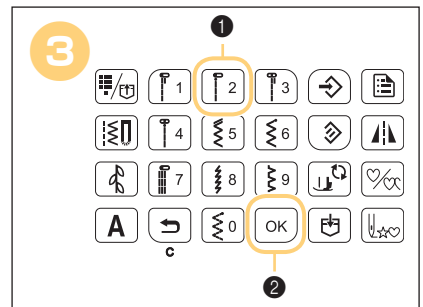
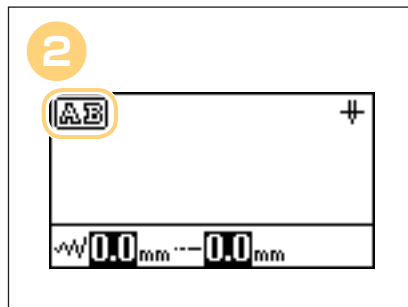
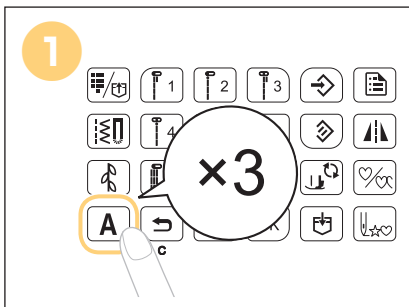



Summary of Stitch Patterns

Resumen de tipos de puntada

Sommaire des motifs de point

◆ Preset Utility Stitches ◆ Puntadas de utilidad predefinidas ◆ Préréglage des points de couture courants



◆ Utility Stitches ◆ Puntadas de utilidad ◆ Points de couture courants

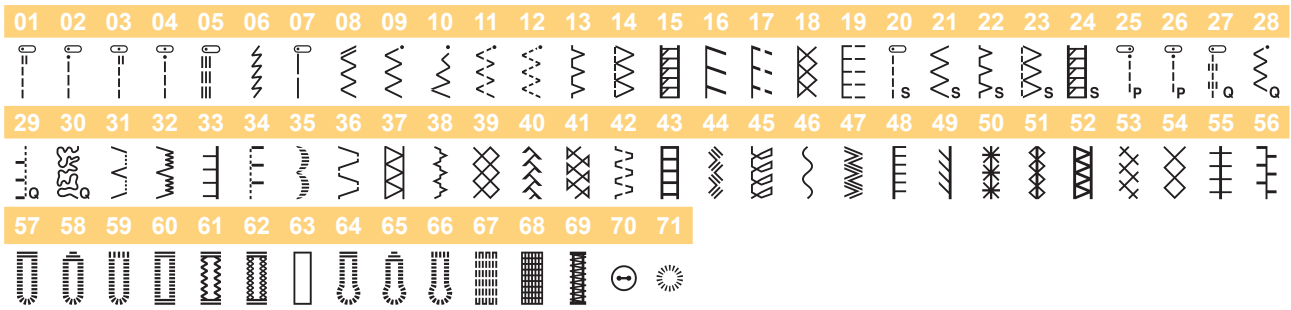

◆ Decorative Stitches ◆ Puntadas decorativas ◆ Points décoratifs



● Decorative Stitches

● Puntadas decorativas

● Points décoratifs

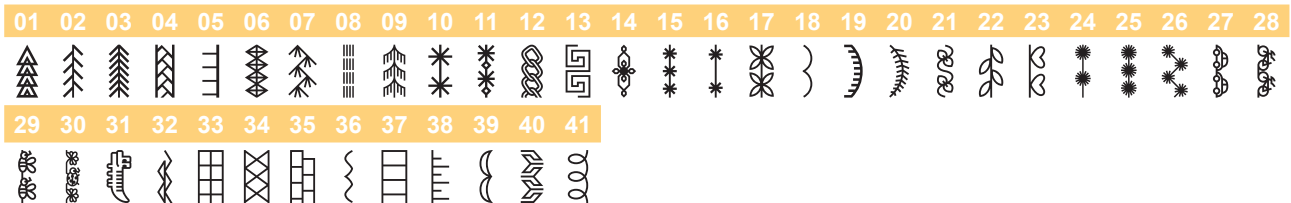

● Satin stitches (01-10)
7 mm satin stitches (11-27)
Cross stitch stitches (28-38)

● Costuras para satén (01-10)
Puntadas satinadas de 7 mm (11-27)
Puntadas de punto de cruz (28-38)

● Points plumetis (01-10)
Points plumetis 7 mm (11-27)
Points de croix (28-38)





● Utility decorative stitch patterns

● Puntadas decorativas utilitarias

● Motifs de points décoratifs courants

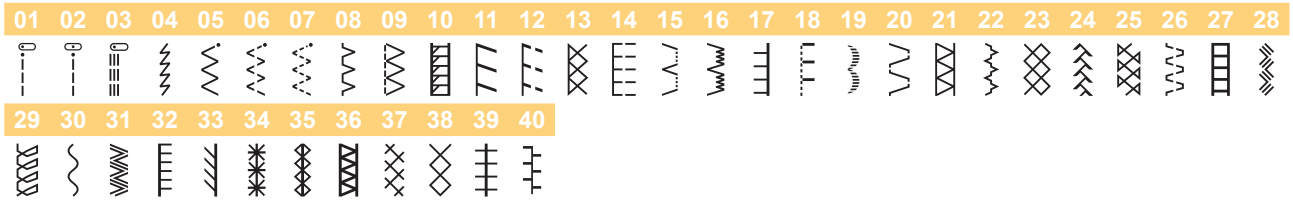

◆ Character Stitches

◆ Puntadas de carácter

◆ Points de caractères



● Gothic font

● Fuente gótica

● Police gothique

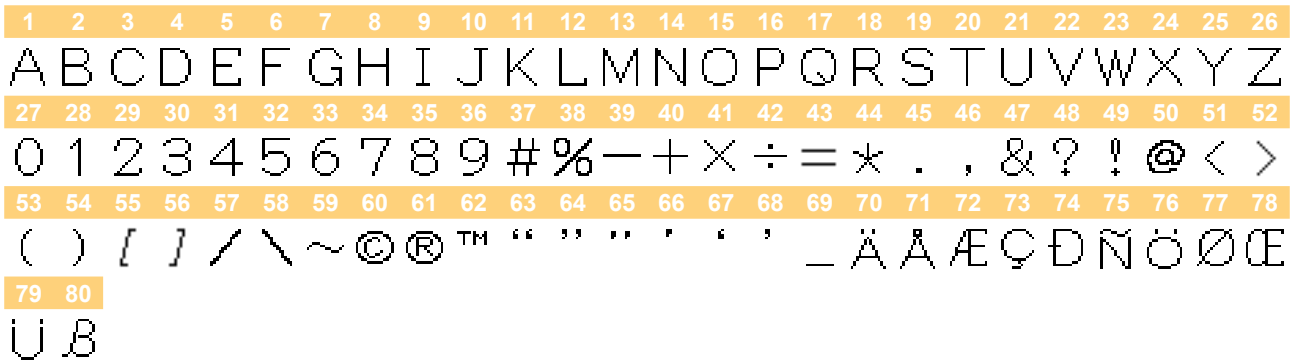

● Handwriting font

● Fuente de escritura a mano

● Police manuscrite

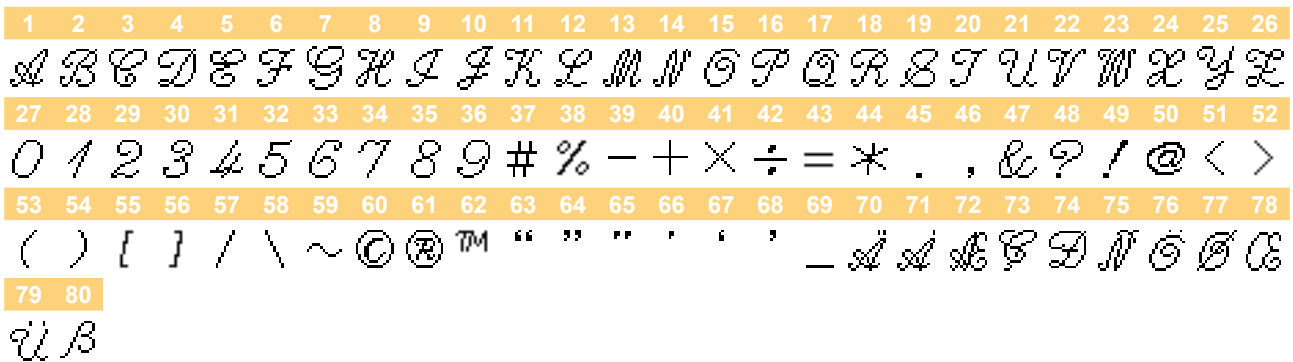

● Outline

● Con borde

● Contour

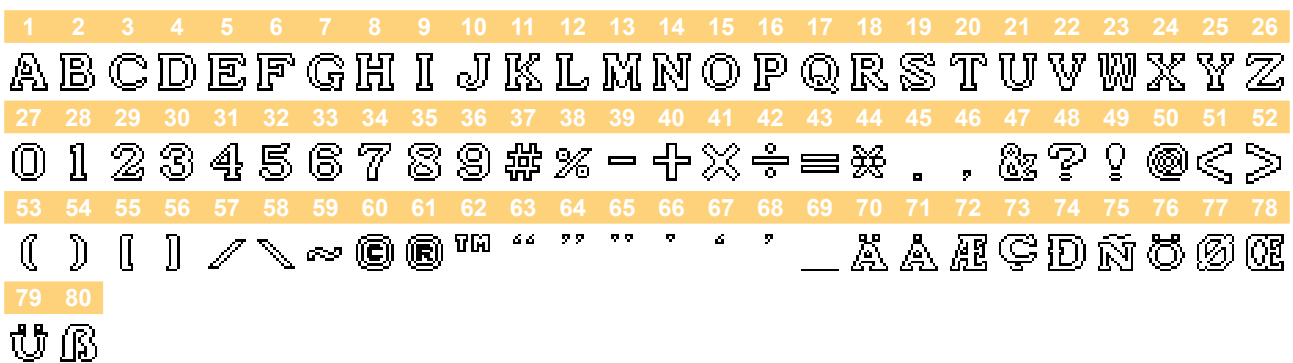

A ×4 ▶ **АБ**

● Cyrillic font

● Fuente cirílica

● Police cyrillique

1	2	3	4	5	6	7	8	9	10	11	12	13	14	15	16	17	18	19	20	21	22	23	24	25	26
А	Б	В	Г	Д	Е	Ё	Ж	З	И	Й	К	Л	М	Н	О	П	Р	С	Т	У	Ф	Х	Ц	Ч	Ш
27	28	29	30	31	32	33	34	35	36	37	38	39	40	41	42	43	44	45	46	47	48	49	50	51	52
Щ	ъ	ы	ь	Э	Ю	Я	Г	Є	І	і	Ў	Ѡ	ѡ	Ј	Ј	Ѣ	ѣ	Ѥ	ѥ	Ѧ	ѧ	Ѩ	ѩ	Ѫ	ѫ
53	54	55	56	57	58	59	60	61	62	63	64	65	66	67	68										
5	6	7	8	9	—	.	,	&	?	!	()	/	'	_										

A ×5 ▶ **あい**

● Japanese font

● Fuente japonesa

● Police japonaise

1	2	3	4	5	6	7	8	9	10	11	12	13	14	15	16	17	18	19	20	21	22	23	24	25	26
あ	い	う	え	お	あ	い	う	え	お	か	き	く	け	こ	が	ぎ	ぐ	げ	ご	さ	し	す	せ	そ	ざ
27	28	29	30	31	32	33	34	35	36	37	38	39	40	41	42	43	44	45	46	47	48	49	50	51	52
じ	ず	ぜ	ぞ	た	ち	つ	て	と	だ	ぢ	づ	で	ど	っ	な	に	ぬ	ね	の	は	ひ	ふ	へ	ほ	ば
53	54	55	56	57	58	59	60	61	62	63	64	65	66	67	68	69	70	71	72	73	74	75	76	77	78
び	ぶ	べ	ぼ	ぱ	ぴ	ぷ	ぺ	ぽ	ま	み	む	め	も	や	ゆ	よ	ゃ	ゅ	ょ	ら	り	る	れ	ろ	わ
79	80	81	82	83	84	85	86	87	88	89	90	91	92	93	94	95	96	97	98	99	100	101	102	103	104
を	ん	ア	イ	ウ	エ	オ	ァ	ィ	ゥ	ェ	ォ	ヴ	カ	キ	ク	ケ	コ	ガ	ギ	グ	ゲ	ゴ	サ	シ	ス
105	106	107	108	109	110	111	112	113	114	115	116	117	118	119	120	121	122	123	124	125	126	127	128	129	130
セ	ソ	ザ	ジ	ズ	ゼ	ゾ	タ	チ	ツ	テ	ト	ダ	ヂ	ヅ	デ	ド	ッ	ナ	ニ	ヌ	ネ	ノ	ハ	ヒ	フ
131	132	133	134	135	136	137	138	139	140	141	142	143	144	145	146	147	148	149	150	151	152	153	154	155	156
へ	ホ	バ	ビ	ブ	ベ	ボ	パ	ピ	プ	ペ	ポ	マ	ミ	ム	メ	モ	ヤ	ユ	ャ	ュ	ョ	ラ	リ	ル	
157	158	159	160	161	162	163	164	165	166	167	168	169	170	171	172	173	174	175	176	177	178	179	180	181	182
レ	ロ	ワ	ヲ	ン	0	1	2	3	4	5	6	7	8	9	〇	—	二	三	四	五	六	七	八	九	十
183	184	185	186	187	188	189	190	191	192	193	194	195	196	197	198	199	200	201	202	203	204	205	206	207	208
&	?	!	()	—	生	年	月	日	才	保	育	幼	稚	園	小	中	学	校	組	部	火	水	木	金
209	210																								
土	_																								

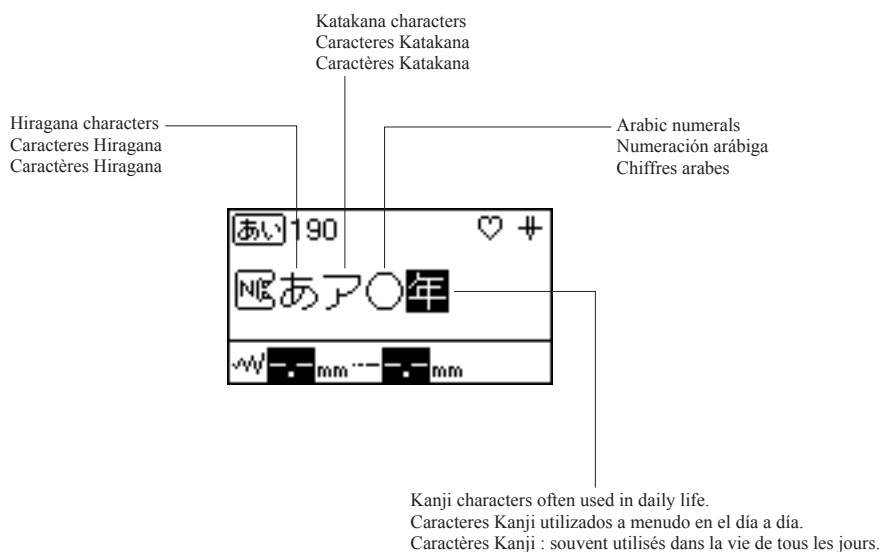

- Example of Kanji characters in daily life
- Ejemplo de caracteres Kanji en la vida cotidiana
- Exemple de caractères Kanji dans la vie quotidienne

一 二 三 四 五 六 七 八 九 十

1, 2, 3, 4, 5, 6, 7, 8, 9, 10

生 年 月 日

Date of birth

Fecha de nacimiento

Date de naissance

一 才

1 year old

1 año de edad

1 an

保 育 園

Nursery school

Guardería

Crèche

幼 稚 園

Kindergarten

Jardín de infancia

École maternelle

小 学 校

Elementary school

Escuela primaria

École primaire

中 学 校

Junior high school

Escuela secundaria

Collège

組

Group/Class

Grupo/Clase

Groupe/Classe

部

Club/Division

Club/División

Club/Division

月

Moon/Monday

Luna/Lunes

Lune/Lundi

火

Fire/Tuesday

Fuego/Martes

Feu/Mardi

水

Water/Wednesday

Agua/Miércoles

Eau/Mercredi

木

Tree/Thursday

Árbol/Jueves

Arbre/Jeudi

金

Gold/Friday

Oro/Viernes

Or/Vendredi

土

Soil/Saturday

Tierra/Sábado

Terre/Samedi

日

Sun/Sunday

Sol/Domingo

Soleil/Dimanche

一 月 一 日 (月)

January 1st (Monday)

1 de enero (lunes)

1er janvier (lundi)

English
Spanish
French

888-F51



XH3159-001