

Aurora™

Quick Reference Guide Guide de Référence Rapide

Model BLMAR



FOR THE LOVE OF SEWING

To register your machine warranty and receive Baby Lock product updates and offers, go to babylock.com/login. If you have questions with registration, visit your Authorized Baby Lock Retailer.

Baby Lock Consumer Helpline: 800-313-4110

www.BabyLock.com

Brought to You by Tacony Corporation®.

Before using your machine for the first time please read the “IMPORTANT SAFETY INSTRUCTIONS” in the Instruction and Reference Guide.

Refer to the Instruction and Reference Guide for detailed instructions.

In this guide, English screens are used for basic explanations.

For details on the built-in embroidery patterns, refer to the Embroidery Design Guide.

Antes de utilizar la máquina por primera vez, lea las “INSTRUCCIONES DE SEGURIDAD IMPORTANTES” en la Guía de referencia y de instrucciones.

Consulte las instrucciones detalladas en la Guía de referencia y de instrucciones.

En esta guía, para las explicaciones básicas se emplean pantallas en inglés.

Para más información acerca de los patrones de bordado integrados, consulte la Guía de diseños de bordado.

Avant d'utiliser votre machine pour la première fois, veuillez lire les « INSTRUCTIONS DE SÉCURITÉ IMPORTANTES » du guide d'instructions et de référence.

Reportez-vous au guide d'instructions et de référence pour des instructions détaillées.

Dans ce guide, des écrans en Anglais sont utilisés pour les explications de base.

Pour les détails sur les motifs de broderie intégrés, reportez-vous au guide de motifs de broderie.

Contents

Wireless Network Connection Functions	2
◆ Operations available with a wireless network connection ...	2
◆ Wireless network connection	3
Winding/Installing the Bobbin	5
Upper Threading	7
Selecting and Sewing Stitches	9
◆ Utility Stitches	9
◆ Decorative Stitches	10
◆ Character stitches	10
Summary of Stitch Patterns	11
◆ Utility Stitches	11
◆ Decorative Stitches	12
◆ Character stitches	13
Preparing to Embroider	16
Selecting Embroidery Patterns	18

Contenido

Funciones de conexión de red inalámbrica	2
◆ Operaciones disponibles con una conexión de red inalámbrica...	2
◆ Conexión de red inalámbrica	3
Devanar/colocar la bobina	5
Hilo superior	7
Seleccionar y coser puntadas	9
◆ Puntadas de utilidad	9
◆ Puntadas decorativas	10
◆ Puntadas de carácter	10
Resumen de tipos de puntada	11
◆ Puntadas de utilidad	11
◆ Puntadas decorativas	12
◆ Puntadas de carácter	13
Preparativos para bordar	16
Seleccionar patrones de bordado	18

Table des matières

Fonctions de connexion au réseau sans fil	2
◆ Opérations disponibles avec une connexion au réseau sans fil ...	2
◆ Connexion au réseau sans fil	3
Bobinage/installation de la canette	5
Enfilage supérieur	7
Sélection et couture de points	9
◆ Points utilitaires	9
◆ Points décoratifs	10
◆ Points de caractères	10
Sommaire des motifs de point	11
◆ Points utilitaires	11
◆ Points décoratifs	12
◆ Points de caractères	13
Préparation de la broderie	16
Sélection des motifs de broderie	18





Wireless Network Connection Functions

Funciones de conexión de red inalámbrica

Fonctions de connexion au réseau sans fil



- ◆ Operations available with a wireless network connection
- ◆ Operaciones disponibles con una conexión de red inalámbrica
- ◆ Opérations disponibles avec une connexion au réseau sans fil

<p> https://www.babylock.com/accessories/software/design-database-transfer</p>	<p>Wirelessly transfer an embroidery pattern from your computer to the machine by using the dedicated Windows application (Design Database Transfer).</p> <p>Transfiera de forma inalámbrica un patrón de bordado desde el ordenador a la máquina utilizando la aplicación específica de Windows (Design Database Transfer).</p> <p>Utilisez une connexion sans fil pour transférer un motif de broderie de votre ordinateur vers la machine grâce à l'application Windows dédiée (Design Database Transfer).</p>
	<p>Wirelessly transfer to the machine an embroidery pattern edited with embroidery editing software (Palette version 11 or later) on a computer. Also, transfer to Palette an embroidery pattern edited on the machine.</p> <p>Transfiera de forma inalámbrica a la máquina un patrón de bordado editado con un programa de edición de bordados (Palette version 11 o posterior) en un ordenador. Igualmente, transfiera a Palette un patrón de bordado editado en la máquina.</p> <p>Utilisez une connexion sans fil pour transférer vers la machine un motif de broderie modifié avec le logiciel d'édition de broderie (Palette version 11 ou ultérieure) sur un ordinateur. Transférez également vers Palette un motif de broderie modifié sur la machine.</p>
<p>When an updated version of the software is available on our website, the wireless LAN key appears as .</p> <p>Cuando en nuestro sitio web está disponible una versión actualizada del software, la tecla de LAN inalámbrica se muestra como .</p> <p>Quand une mise à jour de la version du logiciel est disponible sur notre site Web, la touche du réseau local LAN sans fil apparaît sous la forme .</p>	



When you first turn on the machine, the following message about a wireless LAN connection appears. To set up a connection, touch **OK**, and then continue with step **4**.

Quando se activa la máquina por primera vez, se muestra el siguiente mensaje acerca de una conexión de LAN inalámbrica. Para establecer una conexión, toque **OK** y luego continúe con el paso **4**.

Quand vous mettez la machine sous tension pour la première fois, le message suivant apparaît, à propos de la connexion au réseau local LAN sans fil. Pour configurer une connexion, appuyez sur **OK**, puis continuez en passant à l'étape **4**.

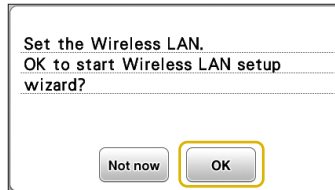

1

Find your security information (SSID and network key) and note it.

Busque su información de seguridad (SSID y clave de red) y anótela.

Recherchez vos informations de sécurité (SSID et clé réseau) et notez-les.

2

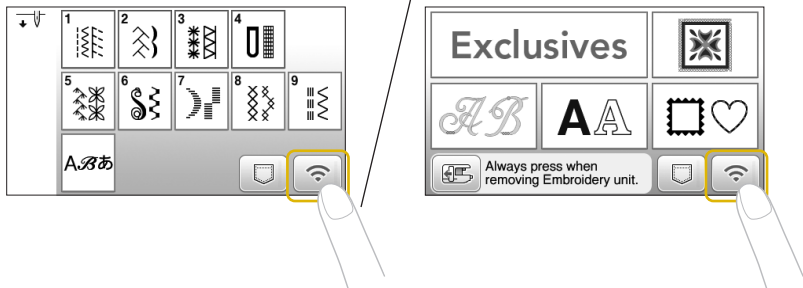

3

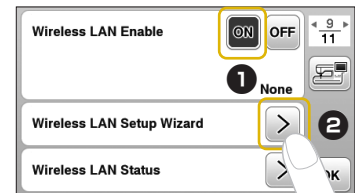

4

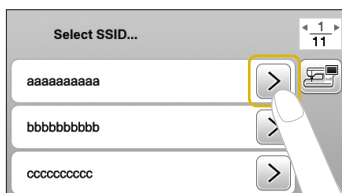

Touch **>** beside the SSID that was noted in step **1**.

- When displaying next or previous pages, touch **<** or **>** key to search the SSID that was noted.

Toque **>** que se muestra junto al SSID que se ha anotado en el paso **1**.

- Cuando se muestren las páginas siguientes o anteriores, toque la tecla **<** o **>** para buscar el SSID que se ha anotado.

Appuyez sur **>** à côté du SSID que vous avez noté lors de l'étape **1**.

- Lorsqu'une page suivante ou précédente est affichée, appuyez sur **<** ou **>** pour chercher le SSID que vous avez noté.

5

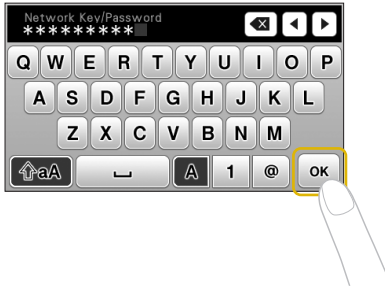

Enter the network key (password) that was noted, and then touch **OK**.

Seleccione la clave de red (contraseña) que se ha anotado y toque **OK**.

Saisissez la clé réseau (mot de passe) que vous avez notée, puis appuyez sur **OK**.

6

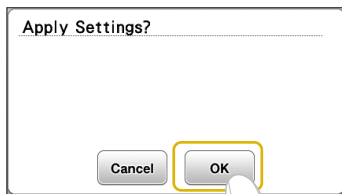

7

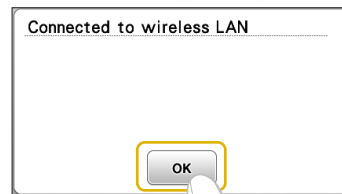

8

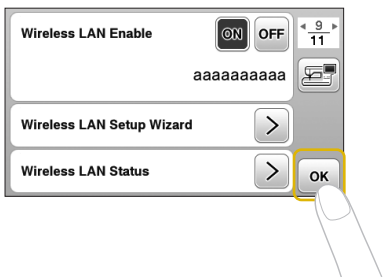

Touch **OK** to exit the setup.

Toque **OK** para salir de la configuración.

Appuyez sur **OK** pour quitter la procédure de configuration.



Winding/Installing the Bobbin

Devanar/colocar la bobina

Bobinage/installation de la canette

Follow the steps below in numerical order. Refer to the Instruction and Reference Guide for detailed instructions.

Siga los pasos descritos a continuación, en orden numérico. Consulte las instrucciones detalladas en la guía de referencia y de instrucciones.

Respectez les étapes ci-dessous, dans l'ordre numérique. Reportez-vous au guide d'instructions et de référence pour des informations détaillées.

Use the plastic bobbin that comes with this machine or bobbins of the same type.

Utilice la bobina de plástico suministrada con esta máquina o bobinas del mismo tipo.

Utilisez la canette en plastique fournie avec cette machine ou des canettes du même type.

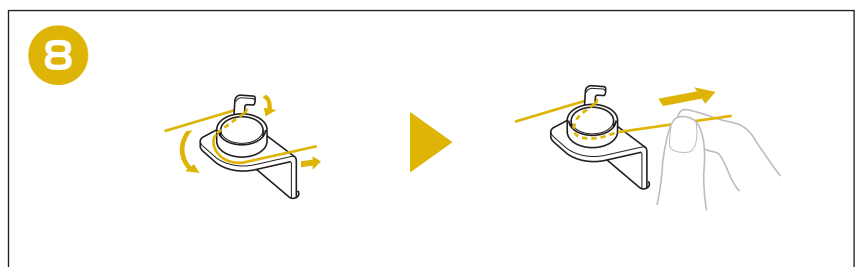
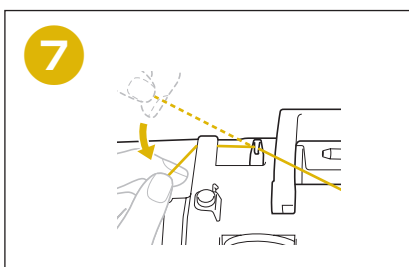
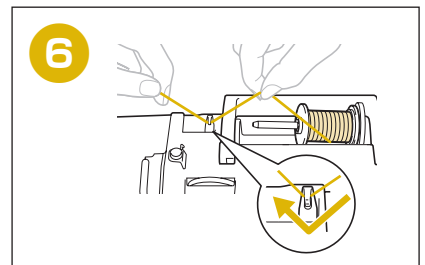
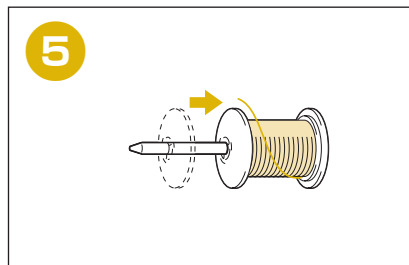
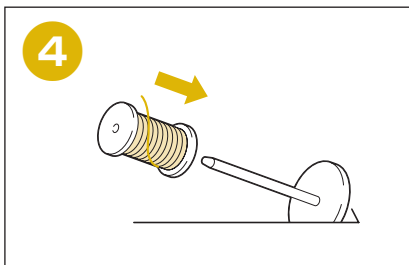
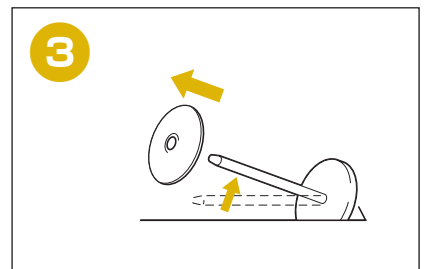
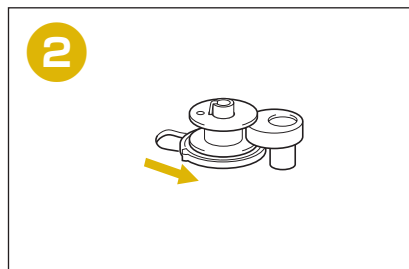
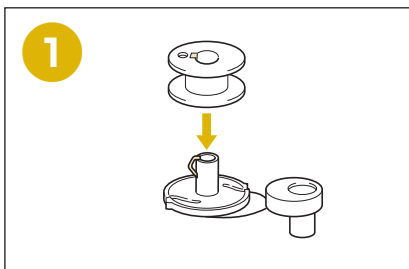
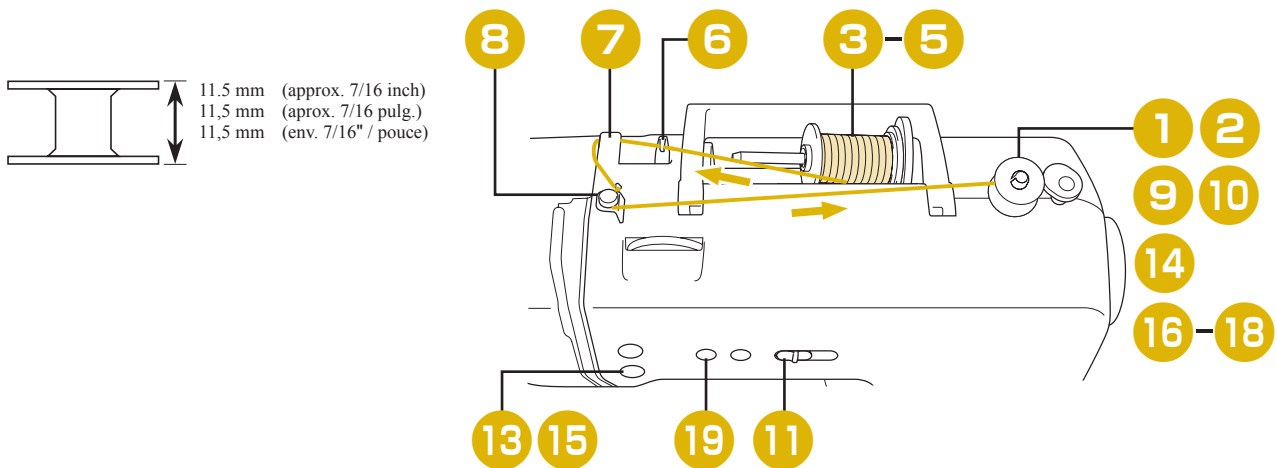

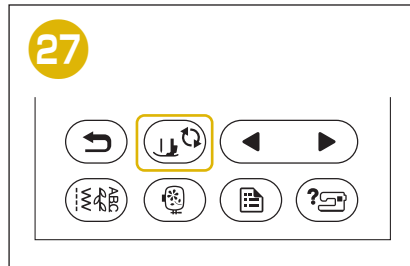
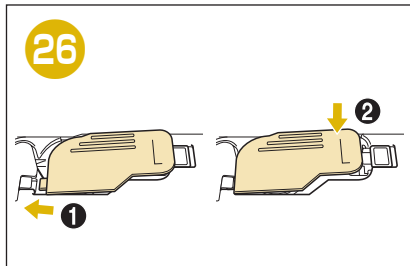
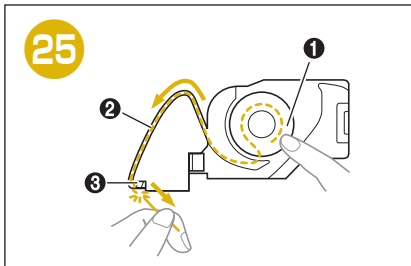
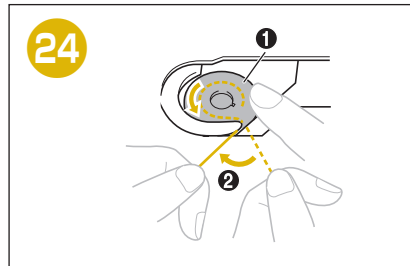
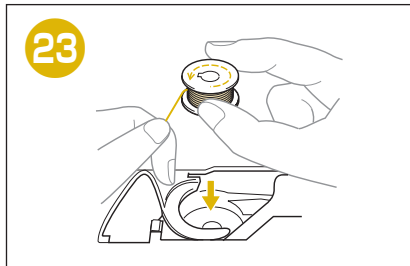
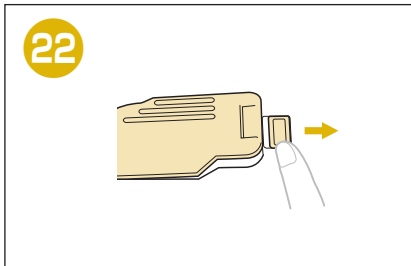
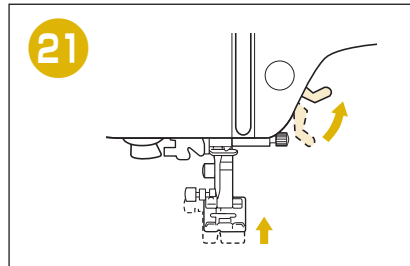
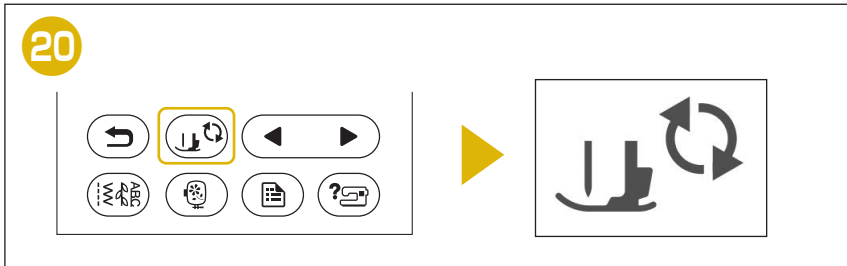
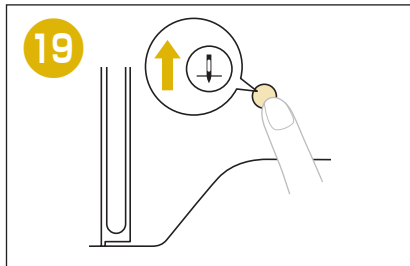
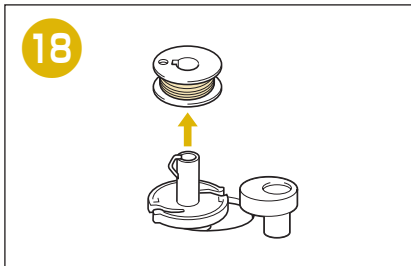
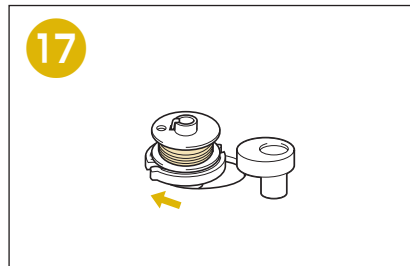
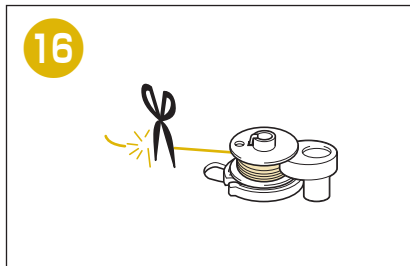
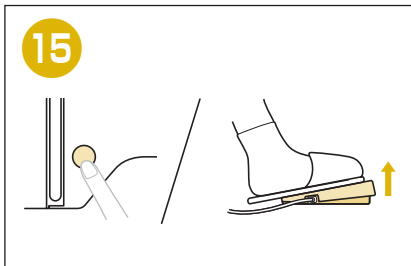
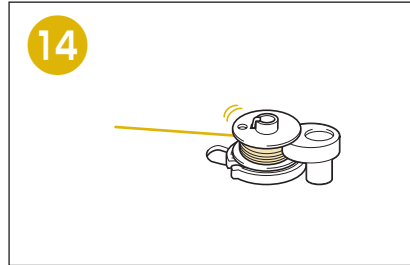
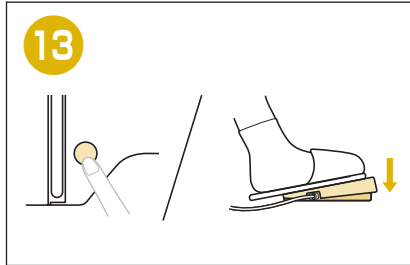
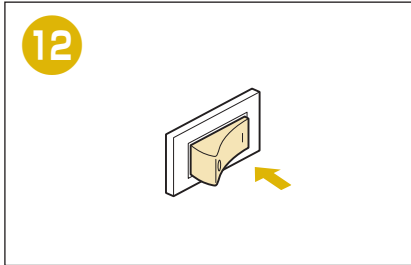
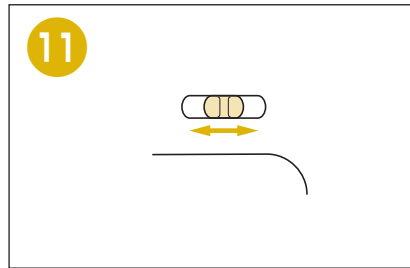
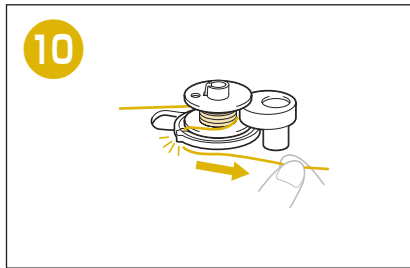
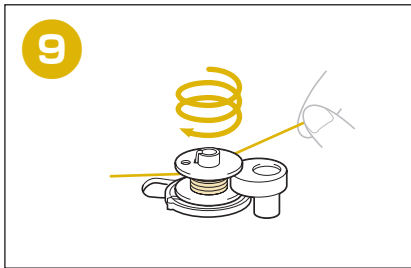



Upper Threading

Hilo superior

Enfilage supérieur

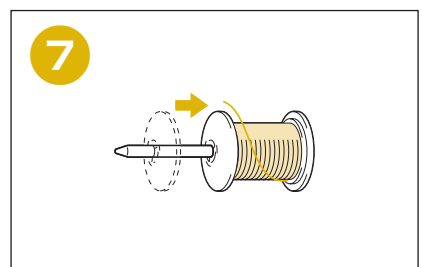
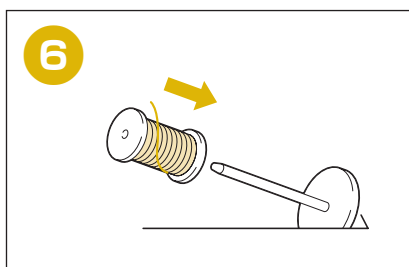
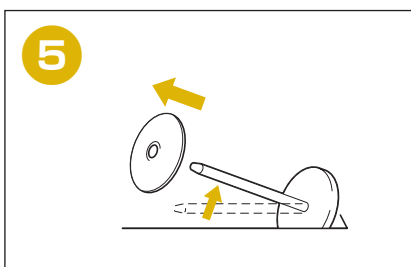
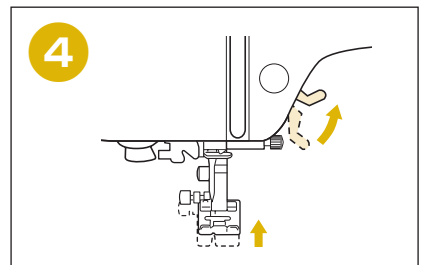
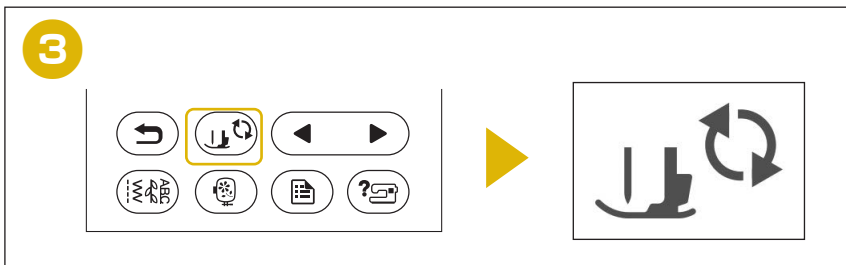
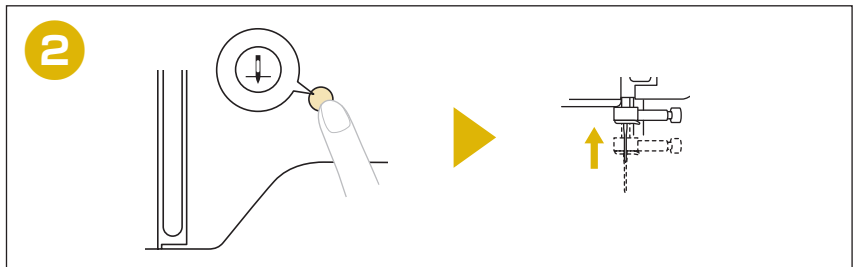
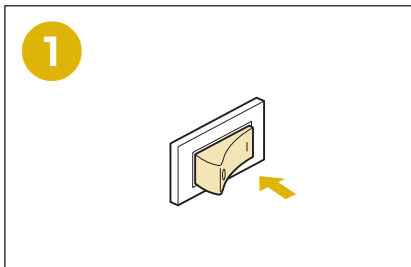
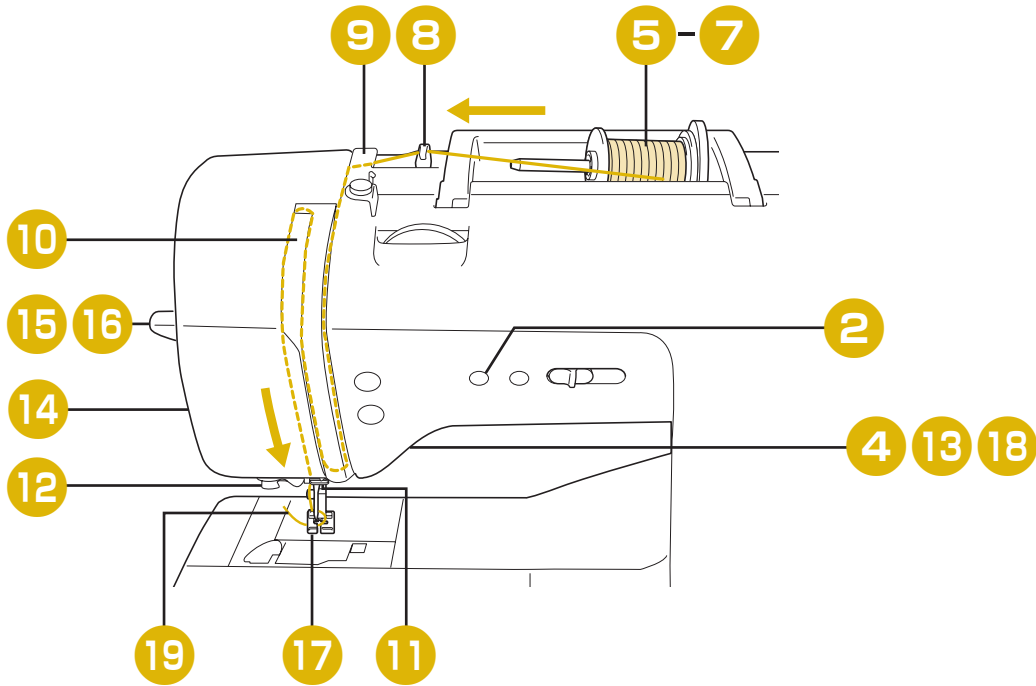

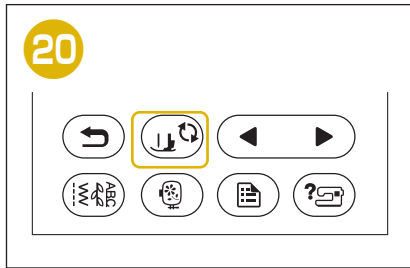
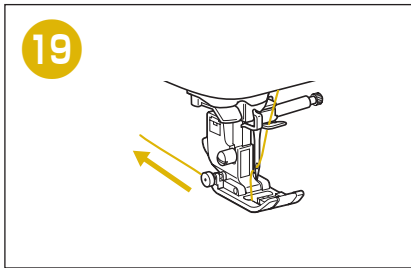
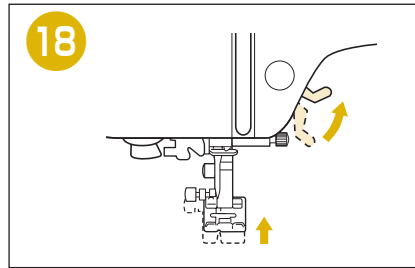
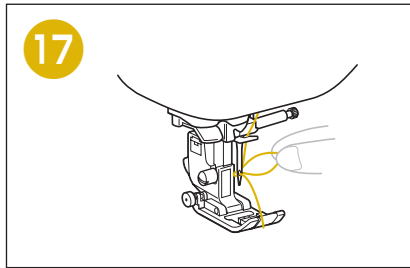
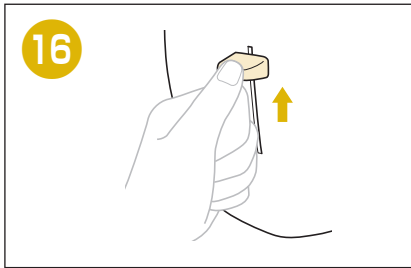
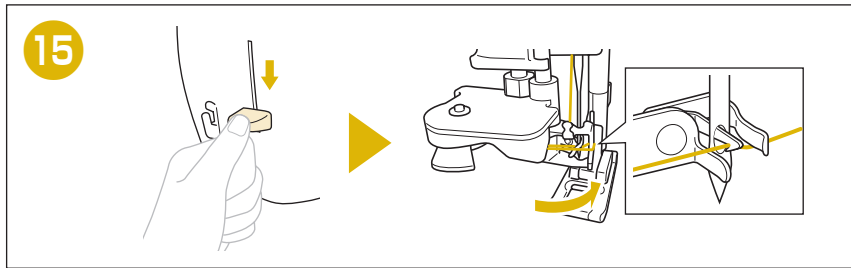
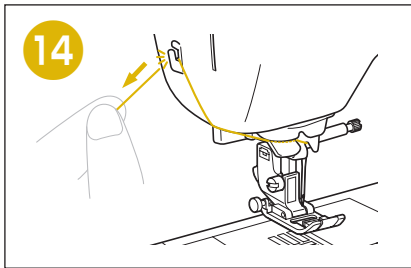
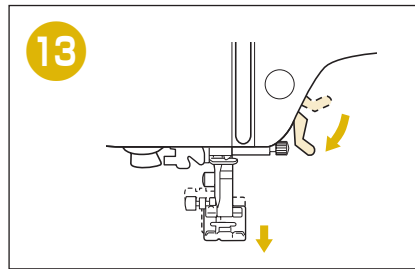
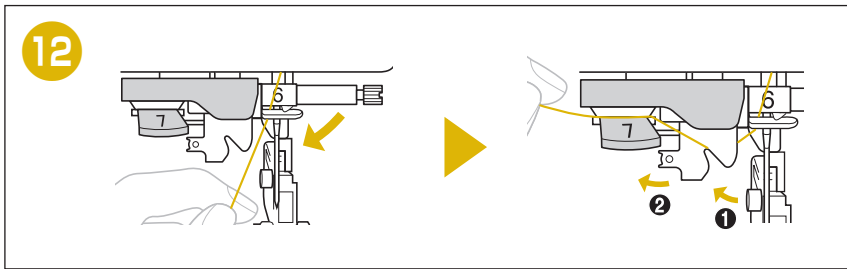
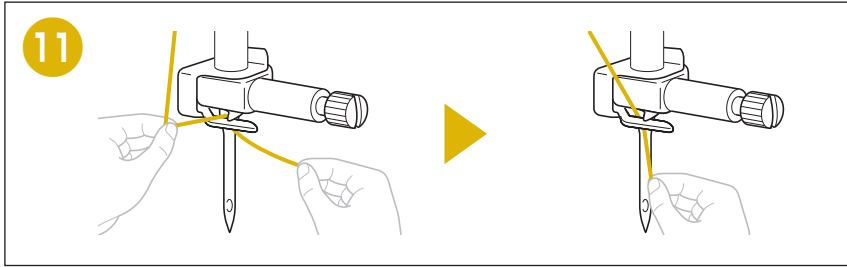
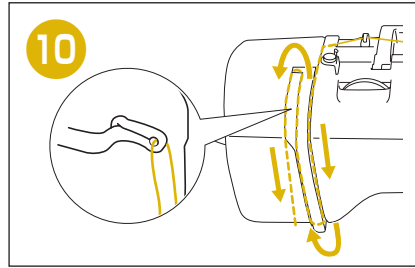
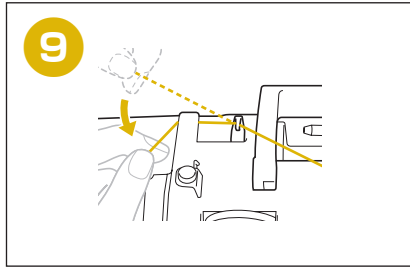
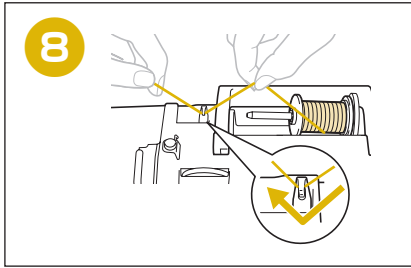

Selecting and Sewing Stitches

Seleccionar y coser puntadas

Sélection et couture de points

◆ Utility Stitches

◆ Puntadas de utilidad

◆ Points utilitaires

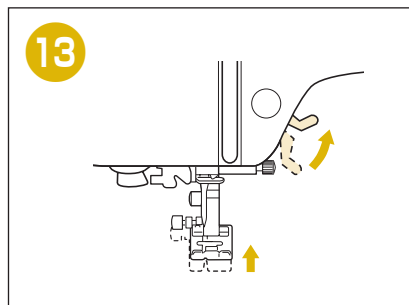
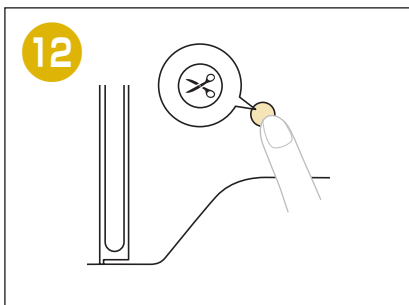
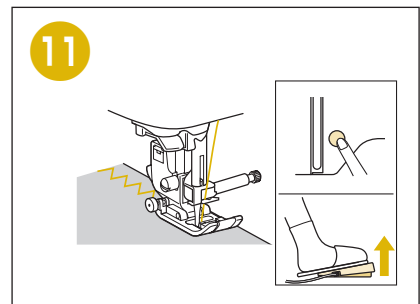
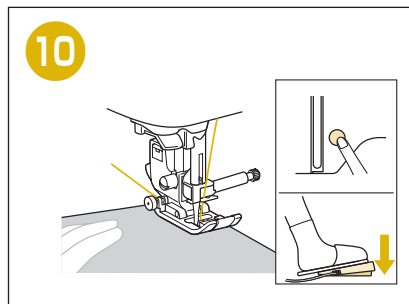
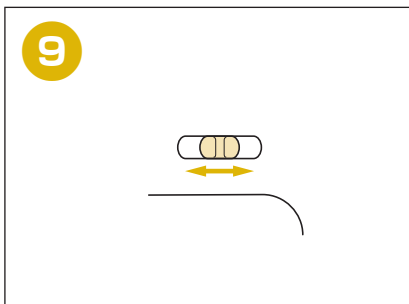
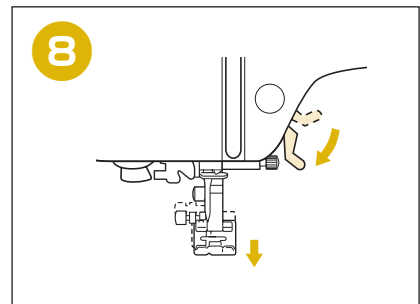
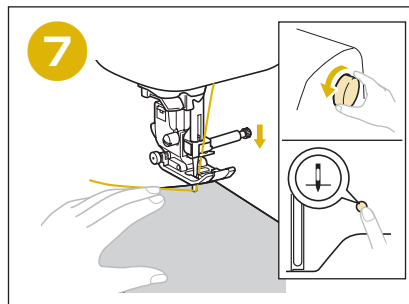
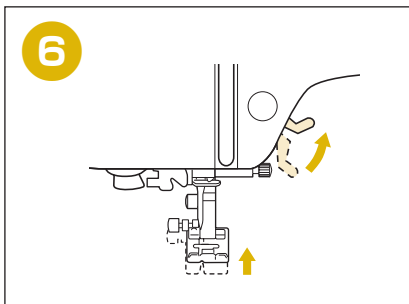
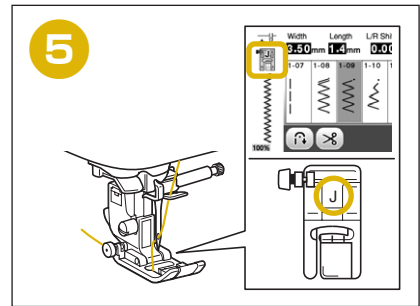
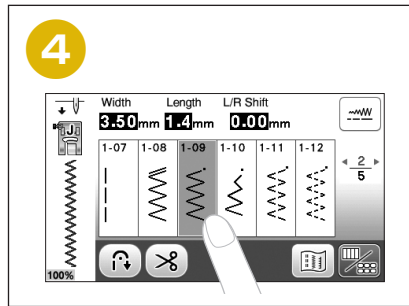
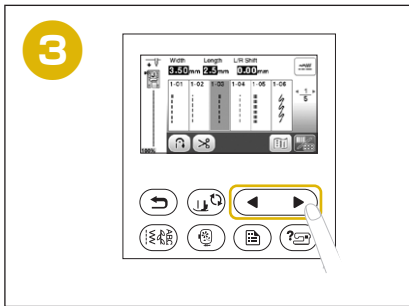
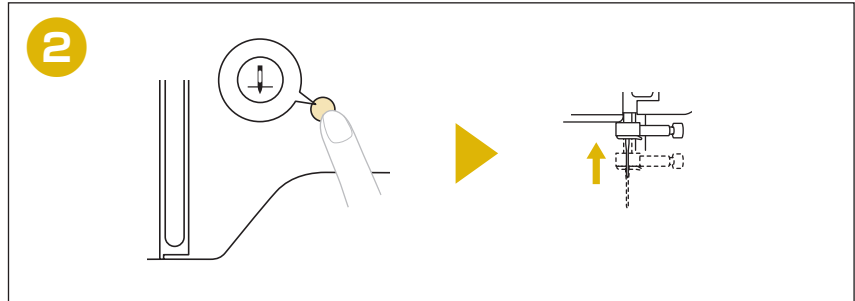
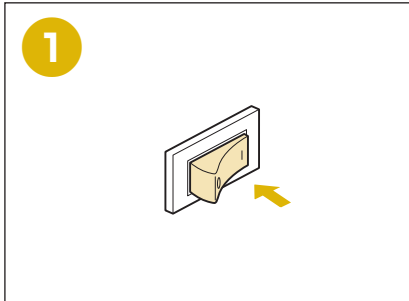

◆ Decorative Stitches

◆ Puntadas decorativas

◆ Points décoratifs

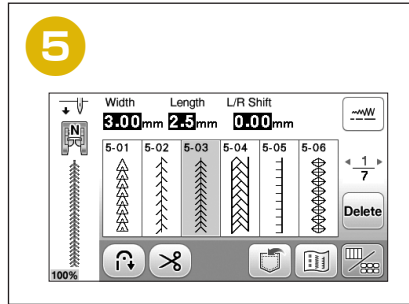
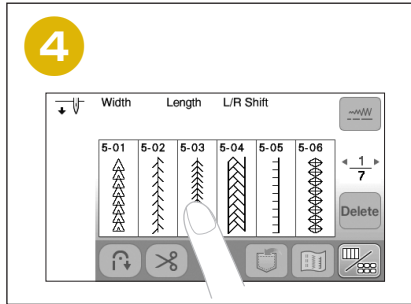
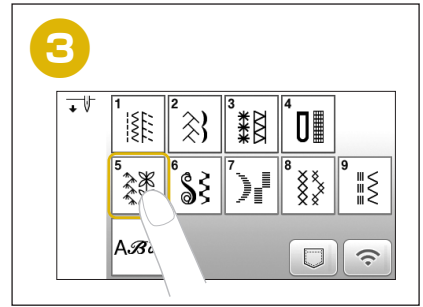
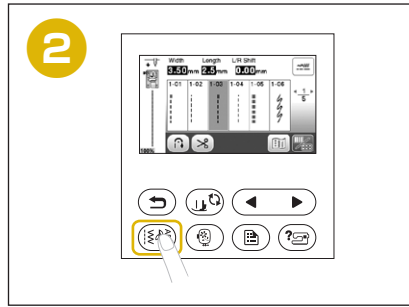
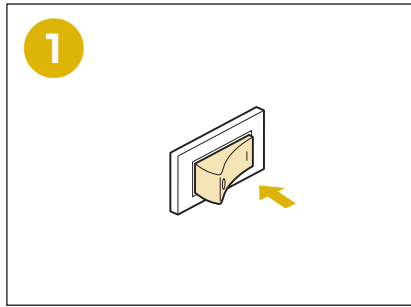

◆ Character stitches

◆ Puntadas de carácter

◆ Points de caractères

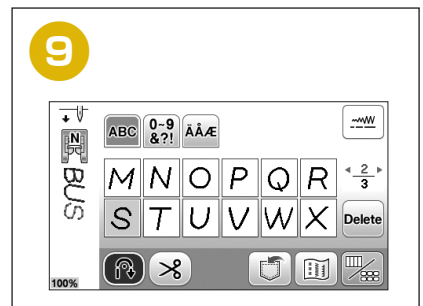
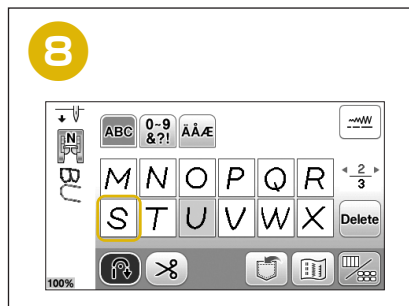
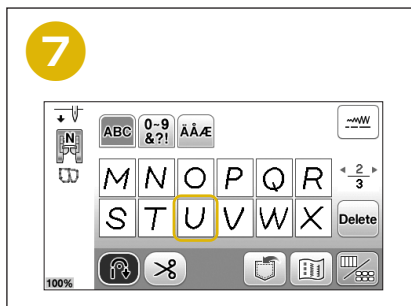
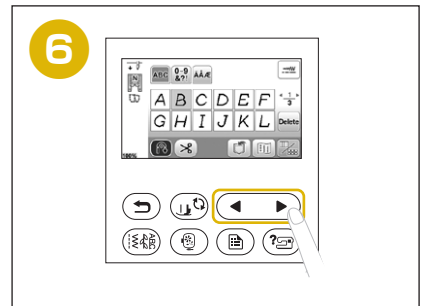
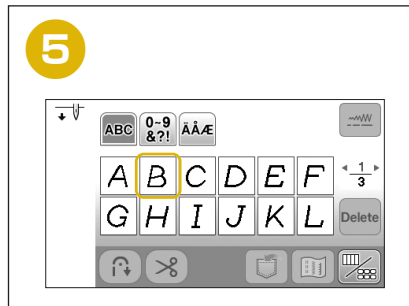
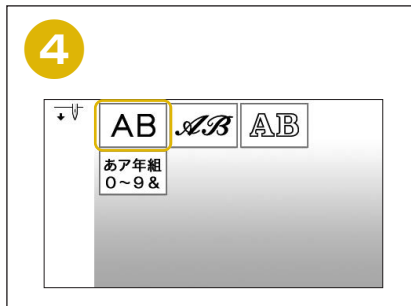
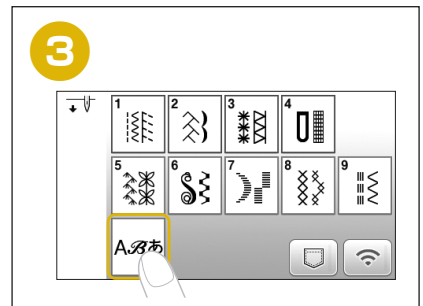
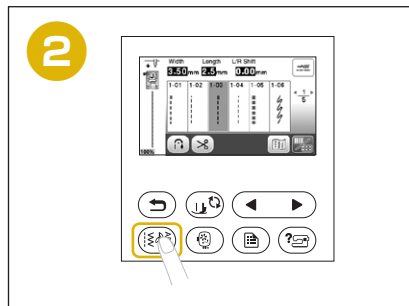
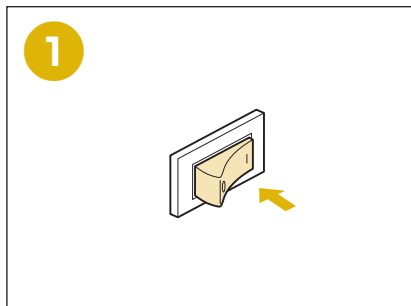



Summary of Stitch Patterns

Resumen de tipos de puntada

Sommaire des motifs de point

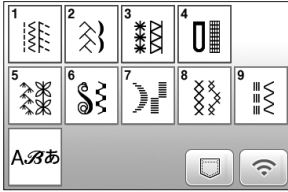

◆ Utility Stitches

◆ Puntadas de utilidad

◆ Points utilitaires

• 1-01~1-30

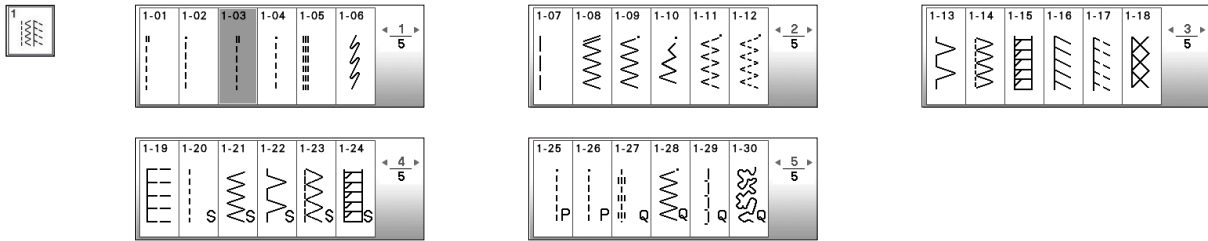

• 2-01~2-17

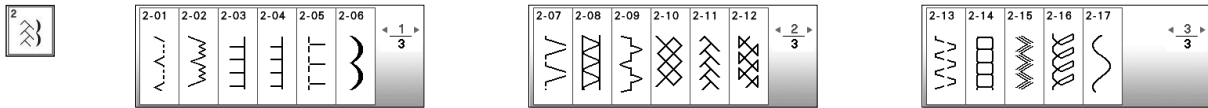

• 3-01~3-10

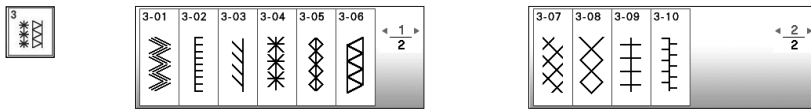

• 4-01~4-15

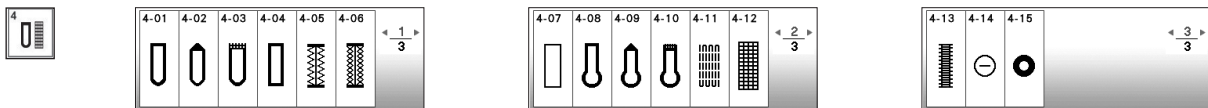

◆ Decorative Stitches

◆ Puntadas decorativas

◆ Points décoratifs

• 5-01~5-41

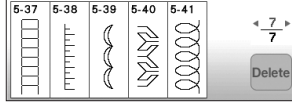
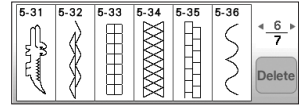
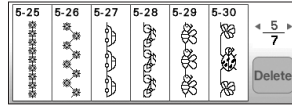
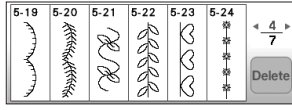
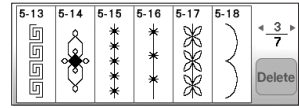
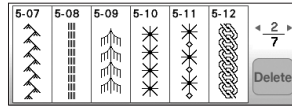
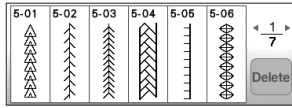

• 6-01~6-10

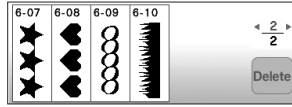
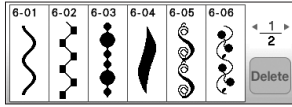

• 7-01~7-17

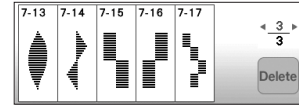
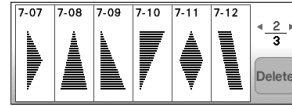
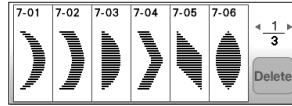

• 8-01~8-11

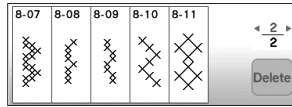
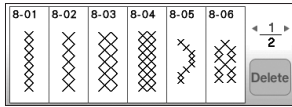

• 9-01~9-40

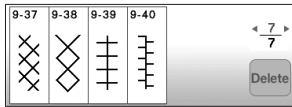
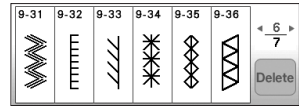
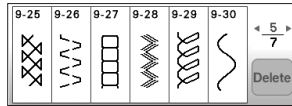
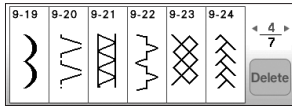
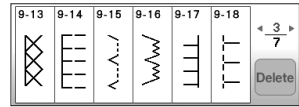
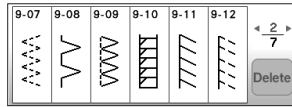
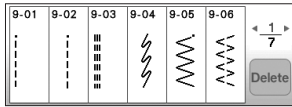

◆ Character stitches

◆ Puntadas de carácter

◆ Points de caractères

A: B あ

AB

ABC	0-9	&?!	ÄÄÆ	→NW		
A	B	C	D	E	F	← 1/3 →
G	H	I	J	K	L	Delete

ABC	0-9	&?!	ÄÄÆ	→NW		
M	N	O	P	Q	R	← 2/3 →
S	T	U	V	W	X	Delete

ABC	0-9	&?!	ÄÄÆ	→NW
Y	Z	—	← 3/3 →	
				Delete

ABC	0-9	&?!	ÄÄÆ	→NW		
0	1	2	3	4	5	← 1/4 →
6	7	8	9	#	%	Delete

ABC	0-9	&?!	ÄÄÆ	→NW		
—	+	×	÷	=	*	← 2/4 →
.	,	&	?	!	@	Delete

ABC	0-9	&?!	ÄÄÆ	→NW		
<	>	()	[]	← 3/4 →
/	\	~	©	®	™	Delete

ABC	0-9	&?!	ÄÄÆ	→NW		
“	”	”	’	‘	’	← 4/4 →
—	Delete					

ABC	0-9	&?!	ÄÄÆ	→NW		
Ä	Å	Æ	Ç	Ð	Ñ	← 1/1 →
Ö	Ø	Œ	Û	Ü	—	Delete

A: B あ

AB

ABC	0-9	&?!	ÄÄÆ	→NW		
<i>A</i>	<i>B</i>	<i>C</i>	<i>D</i>	<i>E</i>	<i>F</i>	← 1/3 →
<i>G</i>	<i>H</i>	<i>I</i>	<i>J</i>	<i>K</i>	<i>L</i>	Delete

ABC	0-9	&?!	ÄÄÆ	→NW		
<i>M</i>	<i>N</i>	<i>O</i>	<i>P</i>	<i>Q</i>	<i>R</i>	← 2/3 →
<i>S</i>	<i>T</i>	<i>U</i>	<i>V</i>	<i>W</i>	<i>X</i>	Delete

ABC	0-9	&?!	ÄÄÆ	→NW
<i>Y</i>	<i>Z</i>	—	← 3/3 →	
				Delete

ABC	0-9	&?!	ÄÄÆ	→NW		
<i>0</i>	<i>1</i>	<i>2</i>	<i>3</i>	<i>4</i>	<i>5</i>	← 1/4 →
<i>6</i>	<i>7</i>	<i>8</i>	<i>9</i>	<i>#</i>	<i>%</i>	Delete

ABC	0-9	&?!	ÄÄÆ	→NW		
—	+	×	÷	=	*	← 2/4 →
.	,	&	?	!	@	Delete

ABC	0-9	&?!	ÄÄÆ	→NW		
<	>	()	[]	← 3/4 →
/	\	~	©	®	™	Delete

ABC	0-9	&?!	ÄÄÆ	→NW		
“	”	”	’	‘	’	← 4/4 →
—	Delete					

ABC	0-9	&?!	ÄÄÆ	→NW		
<i>Ä</i>	<i>Å</i>	<i>Æ</i>	<i>Ç</i>	<i>Ð</i>	<i>Ñ</i>	← 1/1 →
<i>Ö</i>	<i>Ø</i>	<i>Œ</i>	<i>Û</i>	<i>Ü</i>	<i>—</i>	Delete

A: B あ

AB

ABC	0-9	&?!	ÄÄÆ	→NW		
A	B	C	D	E	F	← 1/3 →
G	H	I	J	K	L	Delete

ABC	0-9	&?!	ÄÄÆ	→NW		
M	N	O	P	Q	R	← 2/3 →
S	T	U	V	W	X	Delete

ABC	0-9	&?!	ÄÄÆ	→NW
Y	Z	—	← 3/3 →	
				Delete

ABC	0-9	&?!	ÄÄÆ	→NW		
0	1	2	3	4	5	← 1/4 →
6	7	8	9	#	%	Delete

ABC	0-9	&?!	ÄÄÆ	→NW		
□	+	×	÷	≡	*	← 2/4 →
◦	,	&	?	!	@	Delete

ABC	0-9	&?!	ÄÄÆ	→NW		
<	>	()	[]	← 3/4 →
/	\	~	©	®	™	Delete

ABC	0-9	&?!	ÄÄÆ	→NW		
“	”	”	’	‘	’	← 4/4 →
—	Delete					

ABC	0-9	&?!	ÄÄÆ	→NW		
Ä	Å	Æ	Ç	Ð	Ñ	← 1/1 →
Ö	Ø	Œ	Û	Ü	—	Delete

A.あ

Katakana characters: One of the Japanese character sets.
 Caracteres Katakana: Uno de los diferentes conjuntos de caracteres japoneses.
 Caractères Katakana : Un des ensembles de caractères japonais.

Arabic numerals, Japanese Kanji numerals
 Números arábigos, números Kanji japoneses
 Chiffres arabes, chiffres Kanji japonais

Kanji characters: Often used in daily life / symbols.
 Caracteres Kanji: se utilizan a menudo cotidianamente / como símbolos.
 Caractères Kanji : souvent utilisés dans la vie de tous les jours/symboles.

Hiragana characters: One of the Japanese character sets.
 Caracteres Hiragana: Uno de los diferentes conjuntos de caracteres japoneses.
 Caractères Hiragana : Un des ensembles de caractères japonais.

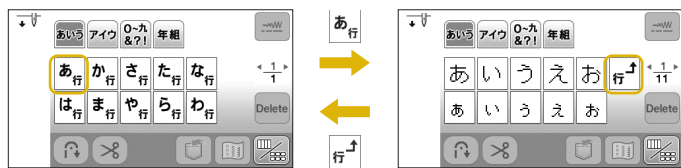

あ行

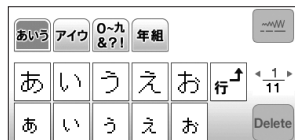

か行

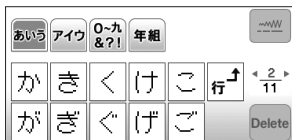

さ行



た行



な行



は行



ま行

や行



ら行

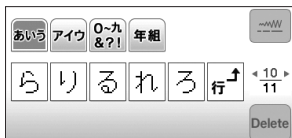

わ行



あいう アイウ 0-9 &?! 年組 --nw

ア行	カ行	サ行	タ行	ナ行
ハ行	マ行	ヤ行	ラ行	ワ行

Delete



あいう アイウ 0-9 &?! 年組 --nw

ア	イ	ウ	エ	オ	行
ア	イ	ウ	エ	オ	ヴ

Delete

ア行

あいう アイウ 0-9 &?! 年組 --nw

ア	イ	ウ	エ	オ	行
ア	イ	ウ	エ	オ	ヴ

Delete

カ行

あいう アイウ 0-9 &?! 年組 --nw

カ	キ	ク	ケ	コ	行
ガ	ギ	グ	ゲ	ゴ	

Delete

サ行

あいう アイウ 0-9 &?! 年組 --nw

サ	シ	ス	セ	ソ	行
ザ	ジ	ズ	ゼ	ゾ	

Delete

タ行

あいう アイウ 0-9 &?! 年組 --nw

タ	チ	ツ	テ	ト	行
ダ	ヂ	ヅ	デ	ド	ッ

Delete

ナ行

あいう アイウ 0-9 &?! 年組 --nw

ナ	ニ	ヌ	ネ	ノ	行
---	---	---	---	---	---

Delete

ハ行

あいう アイウ 0-9 &?! 年組 --nw

ハ	ヒ	フ	ヘ	ホ	行
バ	ビ	ブ	ベ	ボ	

Delete

あいう アイウ 0-9 &?! 年組 --nw

パ	ピ	プ	ペ	ポ	行
---	---	---	---	---	---

Delete

マ行

あいう アイウ 0-9 &?! 年組 --nw

マ	ミ	ム	メ	モ	行
---	---	---	---	---	---

Delete

ヤ行

あいう アイウ 0-9 &?! 年組 --nw

ヤ	ユ	ヨ	行
ヤ	ユ	ヨ	

Delete

ラ行

あいう アイウ 0-9 &?! 年組 --nw

ラ	リ	ル	レ	ロ	行
---	---	---	---	---	---

Delete

ワ行

あいう アイウ 0-9 &?! 年組 --nw

ワ	ヲ	ン	行
---	---	---	---

Delete

あいう アイウ 0-9 &?! 年組 --nw

0	1	2	3	4	5	行
6	7	8	9	○	ー	

Delete

あいう アイウ 0-9 &?! 年組 --nw

二	三	四	五	六	七	行
八	九	十	&	?	!	

Delete

あいう アイウ 0-9 &?! 年組 --nw

()	-	行
---	---	---	---

Delete

あいう アイウ 0-9 &?! 年組 --nw

生	年	月	日	才	保	行
育	幼	稚	園	小	中	

Delete

あいう アイウ 0-9 &?! 年組 --nw

学	校	組	部	火	水	行
木	金	土	行			

Delete

Preparing to Embroider

Preparativos para bordar

Préparation de la broderie

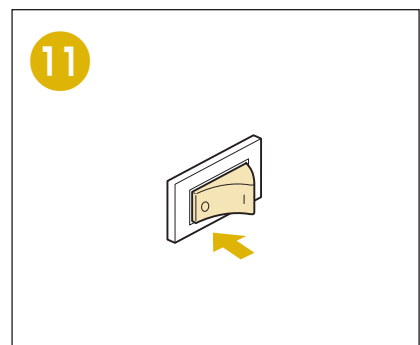
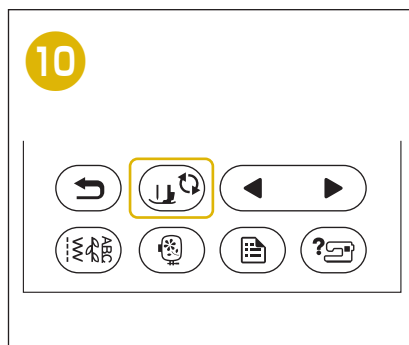
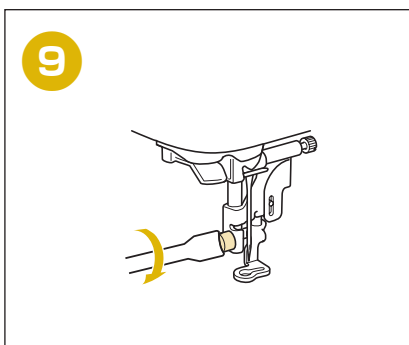
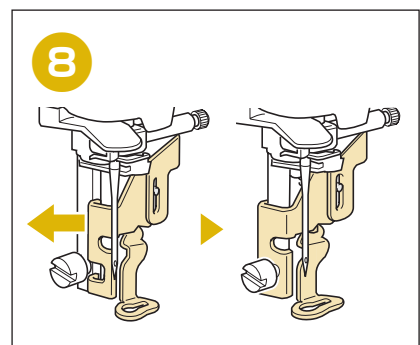
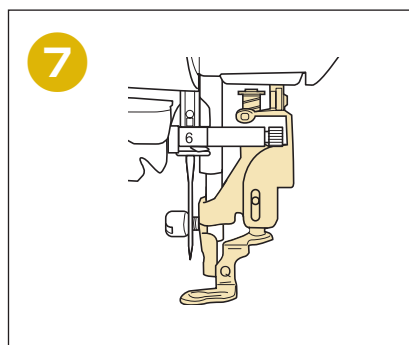
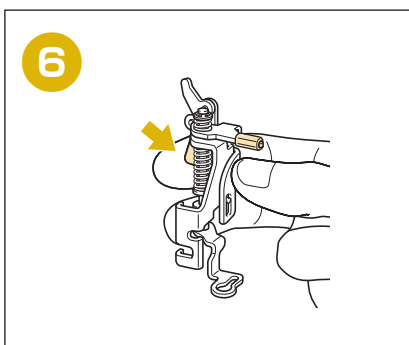
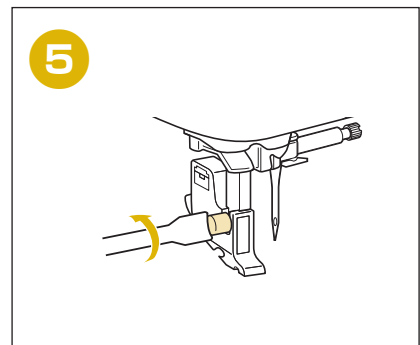
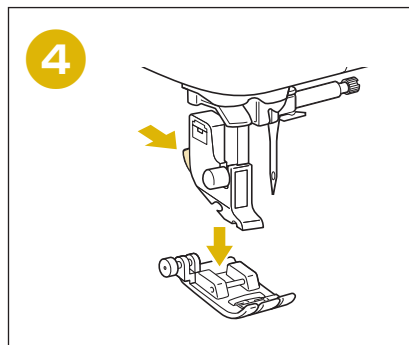
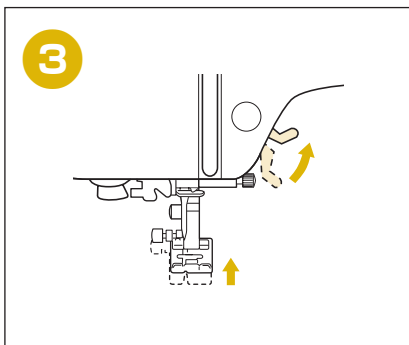
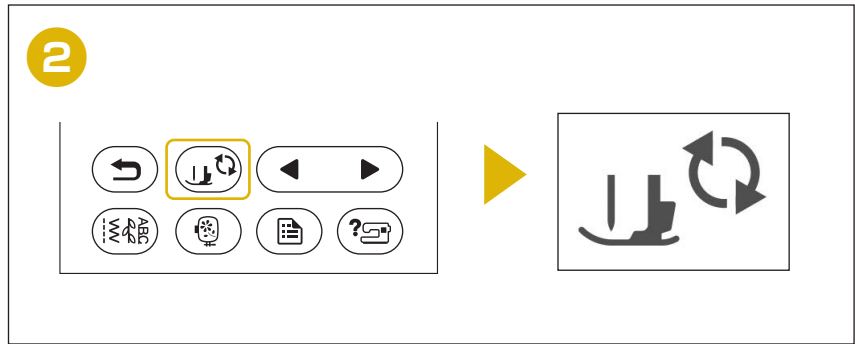
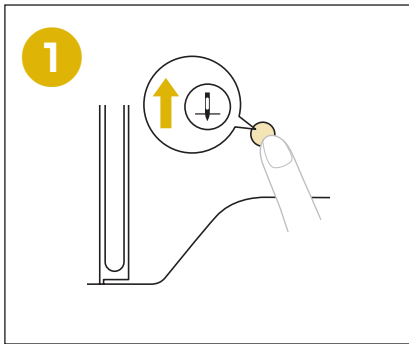

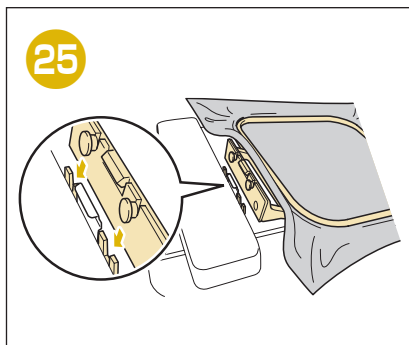
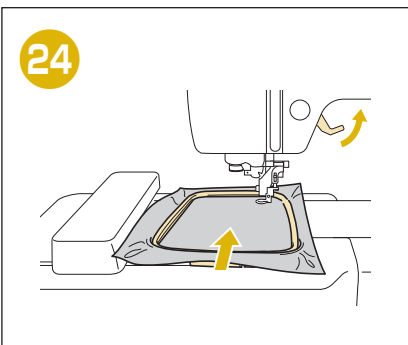
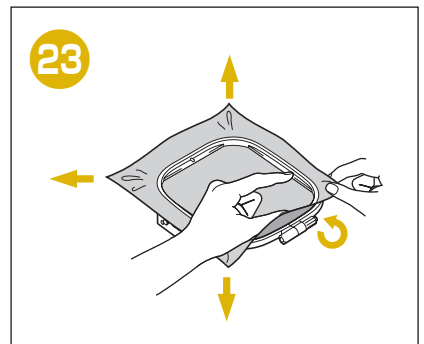
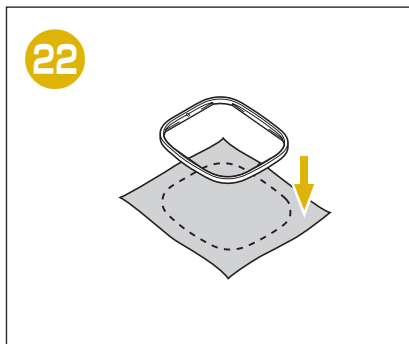
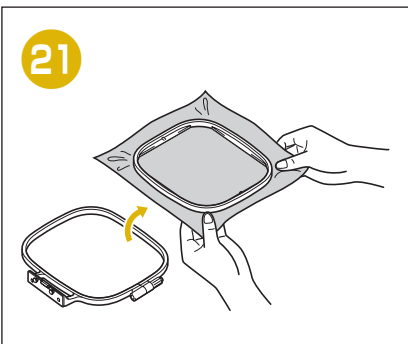
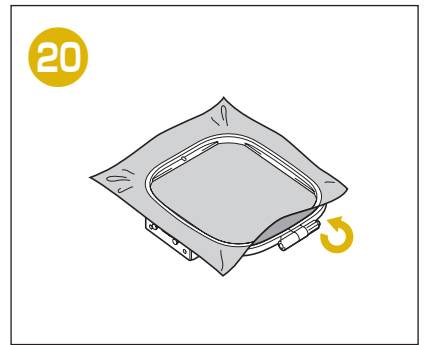
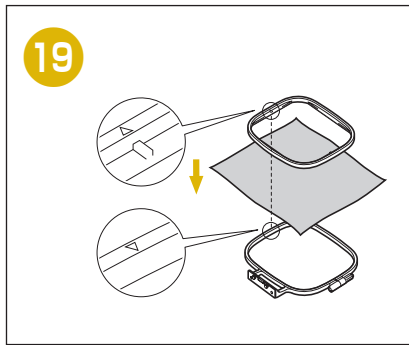
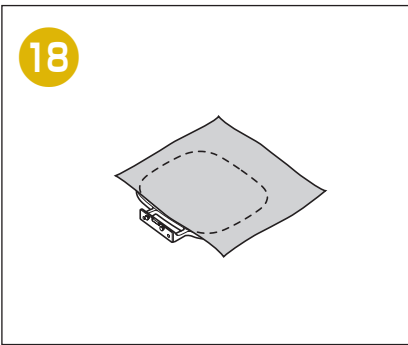
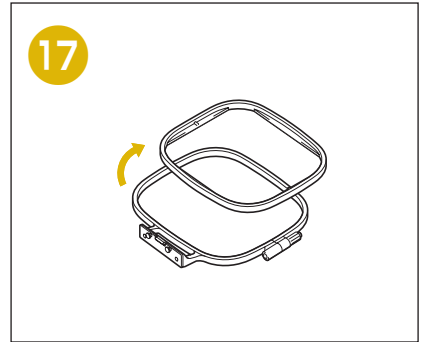
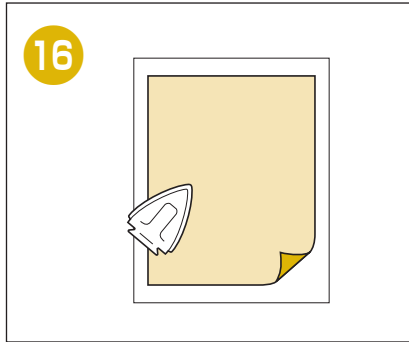
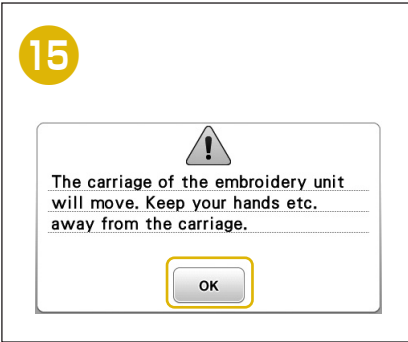
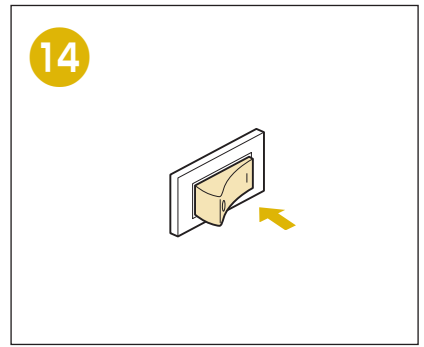
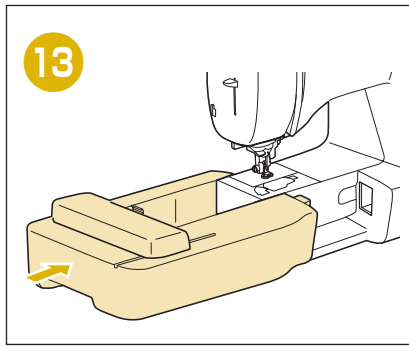
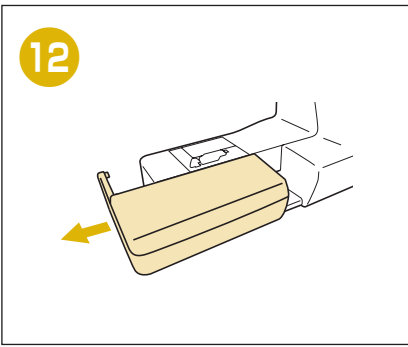

Selecting Embroidery Patterns

Seleccionar patrones de bordado

Sélection des motifs de broderie

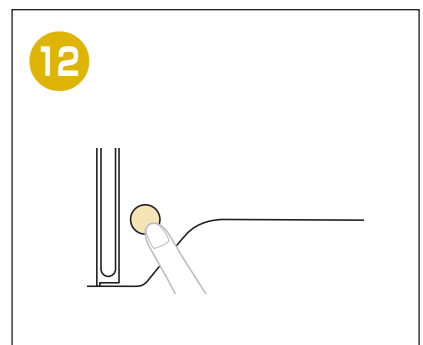
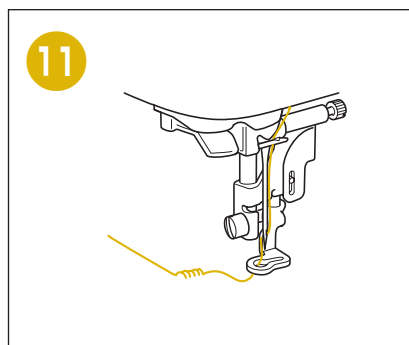
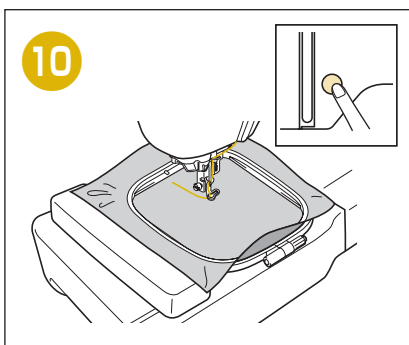
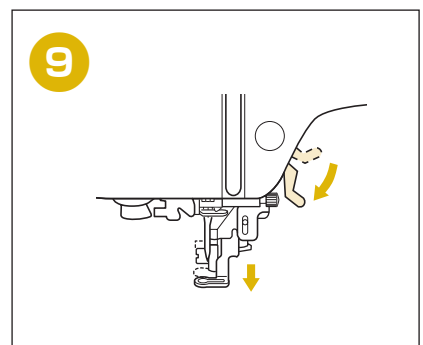
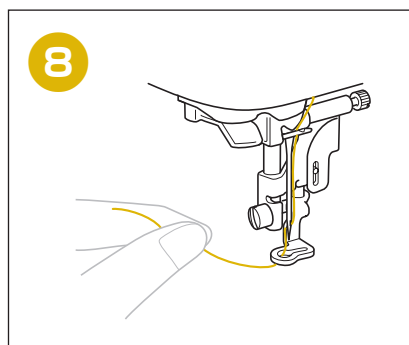
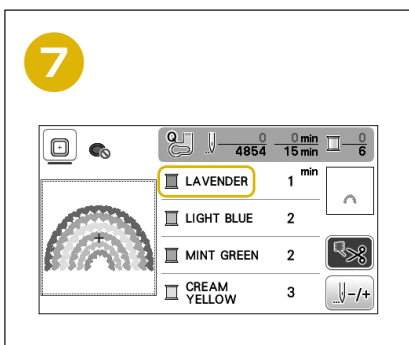
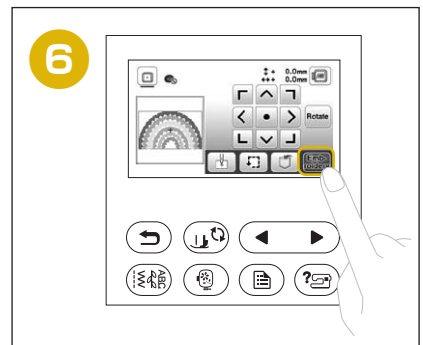
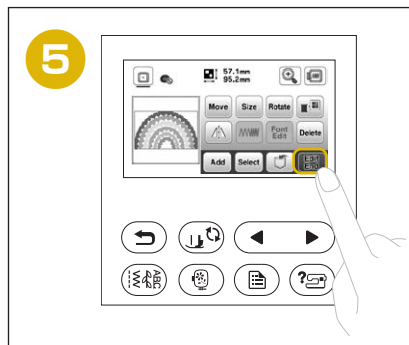
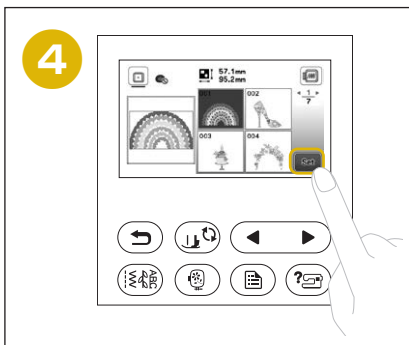
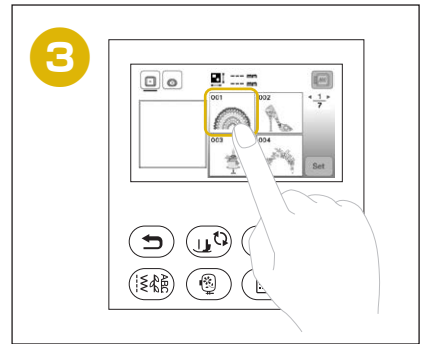
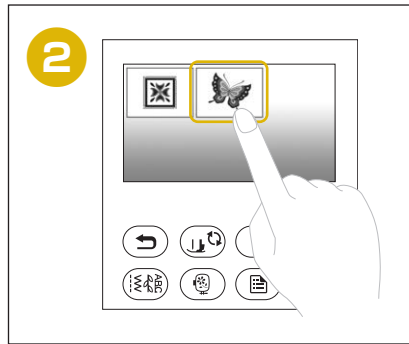
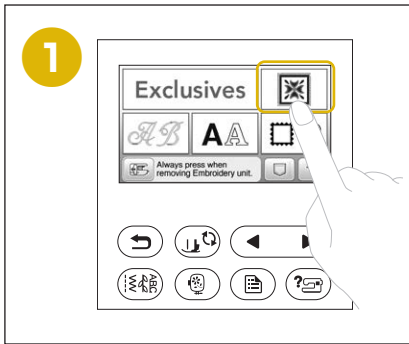

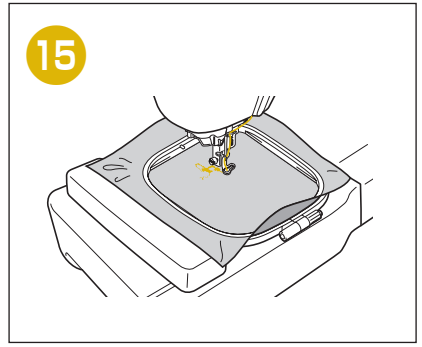
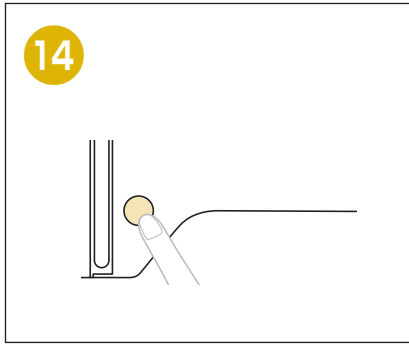
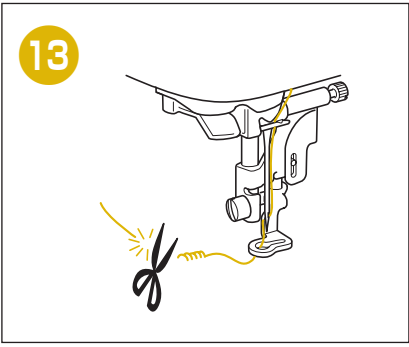





English
Spanish
French
888-P01



D029J9-001